

2-D Electrophoresis

using immobilized pH gradients

Principles and Methods

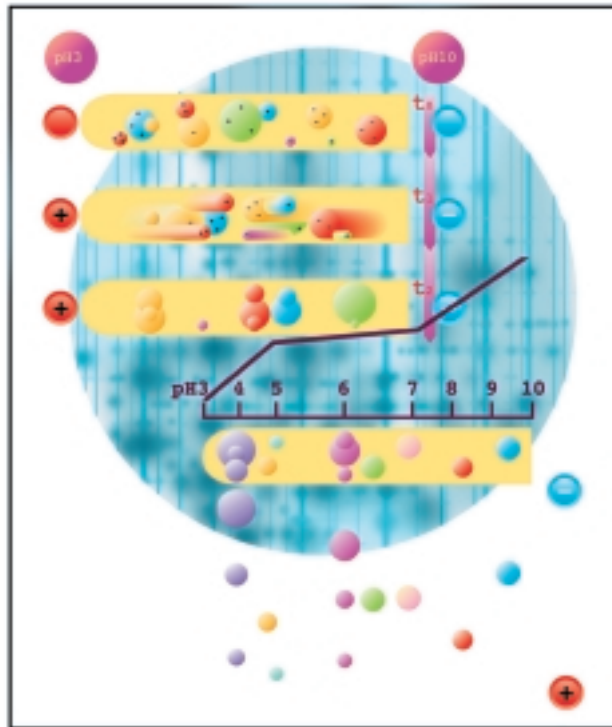

Handbooks from Amersham Biosciences



Antibody Purification

Handbook
18-1037-46

The Recombinant Protein Handbook

Protein Amplification and Simple Purification
18-1142-75

Protein Purification

Handbook
18-1132-29

Ion Exchange Chromatography

Principles and Methods
18-1114-21

Affinity Chromatography

Principles and Methods
18-1022-29

Hydrophobic Interaction Chromatography

Principles and Methods
18-1020-90

Gel Filtration

Principles and Methods
18-1022-18

Reversed Phase Chromatography

Principles and Methods
18-1134-16

Expanded Bed Adsorption

Principles and Methods
18-1124-26

Chromatofocusing

with Polybuffer and PBE
50-01-022PB

Microcarrier cell culture

Principles and Methods
18-1140-62

Percoll

Methodology and Applications
18-1115-69

Ficoll-Paque Plus

For *in vitro* isolation of lymphocytes
18-1152-69

GST Gene Fusion System

Handbook
18-1157-58

2-D Electrophoresis using immobilized pH gradients

Principles and Methods
80-6429-60

2-D Electrophoresis

Principles and Methods

Tom Berkelman and Tirra Stenstedt

with contributions from

Bengt Bjellqvist

Nancy Laird

Michael McDowell

Ingmar Olsson

Reiner Westermeier

Preface

“Proteomics” is the large-scale screening of the proteins of a cell, organism or biological fluid, a process which requires stringently controlled steps of sample preparation, 2-D electrophoresis, image detection and analysis, spot identification, and database searches. The core technology of proteomics is 2-D electrophoresis. At present, there is no other technique that is capable of simultaneously resolving thousands of proteins in one separation procedure.

The replacement of classical first-dimension carrier ampholyte pH gradients with well-defined immobilized pH gradients has resulted in higher resolution, improved interlaboratory reproducibility, higher protein loading capacity, and an extended basic pH limit for 2-D electrophoresis. With the increased protein capacity, micropreparative 2-D electrophoresis has accelerated spot identification by mass spectrometry and Edman sequencing. With immobilized gradients stable as high as pH 12, basic proteins can be separated routinely where previously they were lost due to cathodic drift of carrier ampholyte gradients, or suffered from the limited reproducibility of NEPHGE.

The remarkable improvements in 2-D electrophoresis resulting from immobilized pH gradient gels, together with convenient new instruments for IPG-IEF, will make critical contributions to advances in proteome analysis.

It is my pleasure to introduce this manual on 2-D electrophoresis. It clearly describes the actual and technical basis of the current state-of-the-art 2-D separations using immobilized pH gradients for the first dimension, it provides detailed protocols for new and experienced users, and it includes an extensive bibliography. Finally, there is the pictorial troubleshooting guide—a bit like photos from the album of Murphy’s law that you *wouldn’t dare* include in an official publication—but here they are for all to learn from.

Angelika Görg

Technical University of Munich, August 1998

Contents

Introduction	7
Introduction to the manual	7
Introduction to two-dimensional (2-D) electrophoresis	7
Symbols and abbreviations used in this handbook	8
Choices for first-dimension IEF	9
Choices for second-dimension SDS-PAGE	10
Choices for second-dimension SDS-PAGE	11
Equipment choices	12
Selecting an IEF system	12
Selecting a second-dimension system	13
Multiphor II flatbed system	14
Vertical systems	14
Laboratory technique	15
Chapter 1	
Sample Preparation	17
1.0 Sample preparation—general strategy	17
1.1 Methods of cell disruption	18
1.1.1 Gentle lysis methods	19
1.1.2 More vigorous lysis methods	20
1.2 Protection against proteolysis	21
1.3 Precipitation procedures	22
1.4 Removal of contaminants that affect 2-D results	23
1.5 Composition of sample solution	25
Chapter 2	
First-dimension Isoelectric Focusing (IEF)	27
2.0 First-dimension isoelectric focusing—overview	27
2.1 Background to isoelectric focusing (IEF)	27
2.2 Immobilized pH gradient selection	31
2.3 Sample application method selection	31
2.4 IPG strip rehydration solution	33
2.4.1 Components of the rehydration solution	33
2.4.2 Rehydration solution preparation	35
2.5 Multiphor II and Immobiline DryStrip Kit	35
2.5.1 IPG strip rehydration—Immobiline DryStrip Reswelling Tray	35
2.5.2 Preparing for IEF	37
2.5.3 Sample application by cup loading	38
2.5.4 Paper-bridge loading	39
2.5.5 Isoelectric focusing guidelines	40
2.5.6 Protocol examples—Multiphor II	41
2.5.7 Running a protocol	41
2.5.8 Preservation of focused IPG strips	43
2.5.9 Troubleshooting	43

2.6 Ettan IPGphor Isoelectric Focusing System	44
2.6.1 IPG strip rehydration—Ettan IPGphor Strip Holder	44
2.6.2 IPG strip rehydration—Ettan IPGphor Cup Loading Strip Holder	47
2.6.3 Isoelectric focusing guidelines	51
2.6.4 Protocol examples—Ettan IPGphor	52
2.6.5 Running a protocol	52
2.6.6 Troubleshooting	55

Chapter 3

Second-dimension SDS-PAGE	57
3.0 Second-dimension SDS-PAGE—overview	57
3.1 Background to SDS-PAGE	57
3.2 IPG strip equilibration	58
3.2.1 Equilibration solution components	58
3.2.2 Equilibration steps	59
3.3 The Ettan DALT <i>twelve</i> system	59
3.3.1 Preparation of Ettan DALT <i>twelve</i> Separation Unit for electrophoresis	60
3.3.2 Ettan DALT precast gels	60
3.3.3 Equilibrate the IPG strip	61
3.3.4 Applying the equilibrated IPG strip	61
3.3.5 Insert the precast gel cassettes into the Ettan DALT <i>twelve</i> Separation Unit	63
3.3.6 Electrophoresis conditions	63
3.3.7 Preparing SDS slab gels—vertical systems	64
3.3.8 Troubleshooting	66
3.4 Multiphor II flatbed system	68
3.4.1 ExcelGel preparation	68
3.4.2 Applying the equilibrated IPG strip	69
3.4.3 Electrophoresis conditions	70
3.4.4 Troubleshooting	71

Chapter 4

Visualization and evaluation of results	73
4.0 Visualization of results	73
4.1 Blotting	74
4.2 Evaluation	74
4.3 Standardization of results	75
4.4 Further analysis of protein spots	76
4.4.1 Picking the spots	76
4.4.2 Digestion of the proteins	76
4.4.3 MALDI-ToF mass spectrometry	76

Chapter 5

Troubleshooting	77
5.0 Troubleshooting 2-D results	77

Appendix I	83
Solutions	83
A. Lysis solution	83
B. Rehydration stock solution without IPG Buffer	83
C. Rehydration stock solution with IPG Buffer	84
D. SDS equilibration buffer	84
E. 30% T, 2.6% C monomer stock solution	84
F. 4× resolving gel buffer	85
G. 10% SDS	85
H. 10% ammonium persulfate	85
I. Gel storage solution	85
J. SDS electrophoresis buffer	85
K. Agarose sealing solution	86
Appendix II	87
Optimized silver staining of Ettan DALT gels using PlusOne Silver Staining Kit, Protein	87
References	89
Additional reading and reference material	94
Recommended additional consumables	94
Ordering information	95

Introduction

Introduction to the manual

This handbook is intended as a guideline for performing high-resolution 2-D electrophoresis. Depending on the sample type and the nature of the investigation, the procedures may need to be adjusted or optimized.

The manual is divided into four chapters: Chapter 1 provides guidelines for sample preparation. Chapter 2 details procedures for performing the first-dimension of 2-D electrophoresis. Chapter 3 contains general directions for subsequent second-dimension electrophoresis of immobilized pH gradient (IPG) strips. Chapter 4 discusses visualization and analysis of the 2-D electrophoresis results. The 2-D protocols described herein are performed using Amersham Biosciences products. Equipment choices are discussed on page 12 and illustrated in Table 1.

Introduction to two-dimensional (2-D) electrophoresis

Two-dimensional electrophoresis (2-D electrophoresis) is a powerful and widely used method for the analysis of complex protein mixtures extracted from cells, tissues, or other biological samples. This technique sorts proteins according to two independent properties in two discrete steps: the first-dimension step, isoelectric focusing (IEF), separates proteins according to their isoelectric points (pI); the second-dimension step, SDS-polyacrylamide gel electrophoresis (SDS-PAGE), separates proteins according to their molecular weights (M_r relative molecular weight). Each spot on the resulting two-dimensional array corresponds to a single protein species in the sample. Thousands of different proteins can thus be separated, and information such as the protein pI, the apparent molecular weight, and the amount of each protein is obtained.

Two-dimensional electrophoresis was first introduced by P. H. O'Farrell (1) and J. Klose (2) in 1975. In the original technique, the first-dimension separation was performed in carrier ampholyte-containing polyacrylamide gels cast in narrow tubes. See section 2.1, 'Background to IEF', page 27 for more detail.

The power of 2-D electrophoresis as a biochemical separation technique has been recognized virtually since its introduction. Its application, however, has become significant only in the last few years as a result of a number of developments.

- The introduction of immobilized pH gradients and Immobiline™ reagents (3) brought superior resolution and reproducibility to first-dimension IEF. Based on this concept, A. Görg and colleagues (4,5) developed the currently employed 2-D technique, where carrier ampholyte-generated pH gradients have been replaced with immobilized pH gradients and tube gels replaced with gels supported by a plastic backing. A more detailed discussion of the merits of this technique is presented in section 2.1, 'Background to IEF', page 27.
- New mass spectrometry techniques have been developed that allow rapid identification and characterization of very small quantities of peptides and proteins extracted from single 2-D spots.

- More powerful, less expensive computers and software are now available, rendering thorough computerized evaluations of the highly complex 2-D patterns economically feasible.
- Data about entire genomes (or substantial fractions thereof) for a number of organisms are now available, allowing rapid identification of the gene encoding a protein separated by 2-D electrophoresis.
- The World Wide Web provides simple, direct access to spot pattern databases for the comparison of electrophoresis results and genome sequence databases for assignment of sequence information.

A large and growing application of 2-D electrophoresis is "proteome analysis." Proteome analysis is "the analysis of the entire PROTEin complement expressed by a genOME" (6,7). The analysis involves the systematic separation, identification, and quantification of many proteins simultaneously from a single sample. Two-dimensional electrophoresis is used in this technique due to its unparalleled ability to separate thousands of proteins simultaneously. Two-dimensional electrophoresis is also unique in its ability to detect post- and co-translational modifications, which cannot be predicted from the genome sequence. Applications of 2-D electrophoresis include proteome analysis, cell differentiation, detection of disease markers, monitoring therapies, drug discovery, cancer research, purity checks, and microscale protein purification. This manual describes methods for 2-D electrophoresis using precast IPG strips (Immobiline DryStrip gels) available from Amersham Biosciences.

Symbols and abbreviations used in this handbook



this symbol indicates general advice which can improve procedures or provide recommendations for action under specific situations.



this symbol denotes advice that should be regarded as mandatory and gives a warning when special care should be taken.



this symbol highlights troubleshooting advice to help analyse and resolve difficulties that may occur.



chemicals, buffers, and equipment.



experimental protocol.

PBS phosphate buffered saline (140 mM NaCl, 2.7 mM KCl, 10 mM Na₂HPO₄, 1.8 mM KH₂PO₄, pH 7.4).

Table 1. Equipment choices for 2-D electrophoresis

Choices for first-dimension IEF

Multiphor™ II Electrophoresis Unit with Immobiline DryStrip Kit

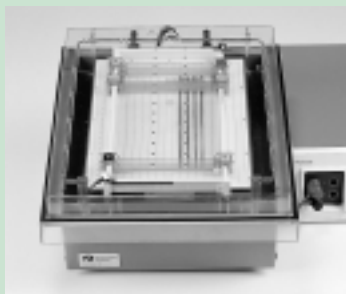

Fig 1. Multiphor II Electrophoresis Unit with Immobiline DryStrip Kit.

Rehydration in Reswelling Tray

IEF in Multiphor II Electrophoresis Unit with Immobiline DryStrip Kit

Choice Factors:

- Multiphor II Electrophoresis Unit can be used for both first- and second-dimension separations.
- Multiphor II is a versatile system. Its use is not limited to IEF with IPG strips from 7 to 24 cm. Several different electrophoresis techniques can be performed with the instrument.

Note: EPS 3501 XL Power Supply and MultiTemp™ III Thermostatic Circulator are required to supply power and cool the system.

Ettan™ IPGphor™ Isoelectric Focusing System



Fig 2. Ettan IPGphor Isoelectric Focusing System.

Rehydration and IEF in Ettan IPGphor Strip Holder

Choice Factors:

- Rehydration, in Ettan IPGphor Strip Holder: Sample application and IEF can be performed overnight, unattended.
- Fewer IPG strip manipulations are required, reducing the chance of error.
- Separations are faster and proteins focus more sharply because of higher voltage.
- Power supply and temperature control are built into the instrument.
- Ettan IPGphor Strip Holders in five different lengths from 7 to 24 cm.
- Ettan IPGphor Cup Loading Strip Holder for all different IPG strip lengths from 7 to 24 cm and for extreme pH gradients.
- Strip holders are serialized for easy sample tracking.

Table 1. Equipment choices for 2-D electrophoresis (continued)

Choices for second-dimension SDS-PAGE

Multiphor II Electrophoresis Unit (flatbed system), 24.5 × 11 cm or 24.5 × 18 cm gels



Fig 3. Multiphor II flatbed system.

Choice Factors:

- Precast gels available: ExcelGel™ SDS 12.5% (24.5 × 11 cm), ExcelGel SDS XL 12–14% (24.5 × 18 cm).
- Relatively rapid: 4 h or less for electrophoresis.
- High resolution.
- All available IPG strip lengths can be used.

Hoefer™ miniVE or SE 260 (mini vertical), 8 × 9 cm gels



Fig 4. Hoefer miniVE.

Choice Factors:

- Rapid: 1–2 h electrophoresis.
- Best for 7 cm IPG strips.

Hoefer SE 600 or Ruby (standard vertical), 14 (or 16) × 15 cm gels

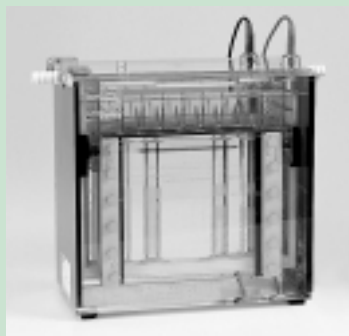

Fig 5. Hoefer SE 600.

Choice Factors:

- 2–5 h electrophoresis.
- Intermediate separation (16 cm gel length).
- Intermediate throughput (up to four gels simultaneously).
- Best for 13 cm IPG strips.

Table 1. Equipment choices for 2-D electrophoresis (continued)

Choices for second-dimension SDS-PAGE

Ettan DALT*twelve* Large Format Vertical System, 26 × 20 cm gels

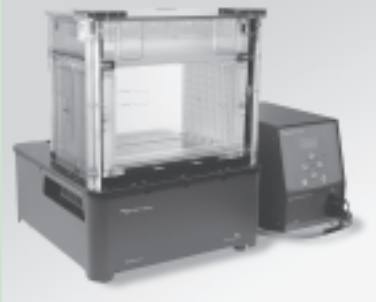

Fig 6. Ettan DALT*twelve* system.

Choice Factors:

- 4 h to overnight electrophoresis.
- Integrated system with very efficient Peltier temperature control.
- Precast gels with stable buffer system, cast on film support, available: Ettan DALT Gel, 12.5% (26 × 20 cm, 1 mm thickness),
- Highest resolution (26 × 20 cm gel size).
- Highest possible protein capacity.
- High throughput (up to 12 gels simultaneously).
- Best for 18 cm and 24 cm IPG strips.
- Low buffer volume: 10 l for 12 gels.

Ettan Spot Picker



Fig 7. Ettan Spot Picker.

Robotic system, which automatically picks selected protein spots from stained or destained gels using a pick list from the image analysis, and transfers them into microplates. The gels need to be cast on a plastic backing or glass plate support.

The 2-D process begins with sample preparation. Proper sample preparation is absolutely essential for a good 2-D result.

The next step in the 2-D process is IPG strip rehydration. IPG strips are provided dry and must be rehydrated with the appropriate additives prior to IEF. First-dimension IEF is performed on a flatbed system at very high voltages with active temperature control. Next, strip equilibration in SDS-containing buffer prepares the sample for the second-dimension separation. Following equilibration, the strip is placed on the second-dimension gel for SDS-PAGE. The final steps are visualization and analysis of the resultant two-dimensional array of spots.

In summary, the experimental sequence for 2-D electrophoresis is:

1. Sample preparation
2. IPG strip rehydration
3. IEF
4. IPG strip equilibration
5. SDS-PAGE
6. Visualization
7. Analysis

Equipment choices

Different options exist in terms of methods and equipment for IEF and SDS-PAGE. Table 1 lists the instruments available from Amersham Biosciences. For detailed information on the operation of any of the instruments described, please also see the respective *User Manual*.

Selecting an IEF system

Amersham Biosciences offers two different systems for the first-dimension separation; the Multiphor II system with associated accessories, and the Ettan IPGphor Isoelectric Focusing System.

Multiphor II (Fig 1) is a versatile system that can be used to perform several different electrophoresis techniques. An advantage of the Multiphor II system for 2-D electrophoresis is the fact that it can be used for both first-dimension IEF and second-dimension SDS-PAGE. Strip rehydration without sample or including sample ("rehydration loading") is performed in the Immobiline DryStrip Reswelling Tray. After rehydration, the IPG strips are transferred to the electrophoresis unit for first-dimension IEF.



The electrophoresis system is comprised of the Multiphor II flatbed unit with Immobiline DryStrip Kit, which also allows cup loading and "paper-bridge loading" of the sample onto rehydrated IPG strips. This system accommodates up to 12 rehydrated IPG strips of the same length for any one IEF protocol. Power is supplied by the EPS 3501 XL power supply and temperature control is provided by the MultiTemp III Thermostatic Circulator.

The Ettan IPGphor Isoelectric Focusing System (Fig 2) further simplifies the first-dimension separation with a system dedicated to IEF separation on IPG strips. The system is comprised of Ettan IPGphor Strip Holders that serve both as rehydration and IEF chambers, and the IPGphor unit, which includes an 8 000 V power supply and built-in temperature control. Programmable parameters include rehydration temperature and duration, IEF temperature and maximum current, and the duration and voltage pattern of multiple steps for one separation. Up to 12 strip holders of the same length can be placed on the Ettan IPGphor platform for any one protocol. Because rehydration loading and IEF are performed consecutively without user intervention, they can be performed unattended overnight.



For gradients at the high and low end of the pH scale, as well as for very high protein loads on narrow pH-range gradient strips, Ettan IPGphor Cup Loading Strip Holder is employed for running the IPG strips gel-side up. Cup Loading Strip Holder allows additional ways of loading the sample; cup loading and paper-bridge loading.



Fewer IPG strip manipulations result in less error, strip mix-up, contamination, air contact, and urea crystallization. Separations are faster because of the substantially higher voltage that can be applied and the better temperature dissipation of the ceramic material of both types of strip holders.

Table 2 shows the key operating differences between the Multiphor II system and the Ettan IPGphor Isoelectric Focusing System for first-dimension IEF.

Table 2. IEF system selection

	Maximum voltage	Additional equipment required	Time required for IEF*
Multiphor II	3 500 V [†]	Immobiline DryStrip Reswelling Tray, Immobiline DryStrip Kit, EPS 3501 XL power supply, MultiTemp III Thermostatic Circulator	2–72 h
IPGphor	8 000 V	Ettan IPGphor Strip Holders of desired length, Cup Loading Strip Holder for 7–24 cm strips, Reswelling Tray for 7–24 cm strips	2–36 h

* Optimal focusing time varies widely depending on the IPG strip length and pH range, and the nature of the sample. Similar separations can generally be performed at least two-fold faster with the IPGphor system than with the Multiphor II system.

† Higher voltages are not recommended for safety reasons.

A graphic guide for the selection of sample application methods and strip holders for Multiphor II as well as for Ettan IPGphor can be found on page 32.

Selecting a second-dimension system

The second-dimension separation may be performed in a flatbed or vertical system. Table 3 matches the appropriate second-dimension system and gel size with IPG strip length. Further considerations are discussed below. For a more complete discussion of the relative merits of flatbed vs. vertical second-dimensions, consult reference 8.

Table 3. Selection of a second-dimension electrophoresis system

	Approx. gel size (w × l, cm)	Number of gels	Gel thickness (mm)	IPG strip length (cm)	Total separation time (h:m)
<i>Flatbed</i>					
Multiphor II, ExcelGel*	24.5 × 11 24.5 × 18	1	0.5	all	1:45 3:20
<i>Vertical</i>					
Hoefer miniVE or SE 260	8 × 9	2	1, 1.5	7	1:30
Hoefer SE 600	14 × 15, 16 × 15 [†] 16 × 7 [‡]	2 or 4 [‡]	1, 1.5	11, 13, 2 × 7	2–5 2–5 1–3
Ettan DALT Gel, 12.5*	26 × 20	12	1	18, 24	5

* Multiple shorter IPG strips (two 11 cm strips or three 7 cm strips) fit on one gel.

† If 1 cm-wide spacers are used.

‡ An accessory divider plate increases the capacity to four gels.

§ Up to 8 mini-format separations can be simultaneously achieved using the shorter (8 cm) glass plates.

Multiphor II flatbed system

This system provides excellent resolution and relatively rapid separations in a large-format gel. Precast ExcelGel products offer the convenience of ready-to-use gels and buffer strips.

The Multiphor II flatbed system (Fig 3, page 10) offers convenience and versatility as it can be used for both first-dimension IEF, as well as second-dimension SDS-PAGE.



The protein loading capacity of an IPG strip can exceed the capacity of the thin, horizontal second-dimension gel, so thicker vertical second-dimension gels are preferred for micro-preparative separations.



The Multiphor II system is not recommended for the second-dimension if pH 6–11 IPG strips have been used for the first-dimension separation.

Vertical systems

Vertical systems offer relative ease of use and the possibility of performing multiple separations simultaneously. Vertical 2-D gels can be either 1 or 1.5 mm thick.

For rapid results, the mini-gel units—Hoefer miniVE (Fig 4, page 10) or SE 260—are recommended. The second-dimension separation is typically complete in 1 to 2 h. The use of mini-gels for the second-dimension of 2-D is ideal when quick profiling is required, or when there are relatively few different proteins in the sample.

For increased throughput and resolution, the standard-sized SE 600 vertical gel system (Fig 5, page 10) is recommended. The SE 600 accommodates up to four 16 cm-long gels, and the built-in heat exchanger offers cooling capability for increased reproducibility. The standard spacer width is 2 cm, giving a 14 cm-wide gel. If additional space for molecular weight markers is desired at both ends of a 13 cm IPG strip, 1 cm-wide spacers are available for the preparation of 16 cm-wide gels.

For maximal resolution, reproducibility, and capacity, the large-gel format of the Ettan DALT*twelve* system (Fig 6, page 11) is recommended. Precast large-format Ettan DALT gels on film support offer the convenience of ready-to-use gels. The system can accommodate the entire length of an 18 and 24 cm IPG strip (plus molecular weight markers) and up to

twelve gels can be run simultaneously. Integrated Peltier temperature control and a buffer circulation pump provide a precise and uniform thermal environment. Up to fourteen 1 mm-thick gels can be cast simultaneously in the Ettan DALT*twelve* Gel Caster.

Laboratory technique



Always wear gloves when handling IPG strips, SDS polyacrylamide gels, ExcelGel Buffer Strips, and any equipment that these items will contact. The use of gloves will reduce protein contamination that can produce spurious spots or bands in 2-D patterns.



Clean all assemblies that will contact the gels or sample with a detergent designed for glassware and rinse well with distilled water. This is particularly important when highly sensitive mass spectrometry techniques are employed for spot identification and characterization.



Always use the highest quality reagents and the purest water available.



Some of the chemicals used in the procedures—acrylamide, N,N'-methylenebisacrylamide, TEMED, ammonium persulfate, and SDS—are extremely hazardous. Acrylamide monomer, for example, is a neurotoxin and suspected carcinogen. You should have a manufacturer's safety data sheet (MSDS) detailing the properties and precautions for all chemicals in your lab. The safety sheets should be reviewed prior to starting the procedures in the manual. General handling procedures for hazardous chemicals include using double latex gloves for all protocols. Hazardous materials should be weighed in a fume hood while wearing a disposable dust mask.

Chapter 1

Sample Preparation

1.0 Sample preparation—general strategy

Appropriate sample preparation is absolutely essential for good 2-D results. Due to the great diversity of protein sample types and origins, only general guidelines for sample preparation are provided in this guide. The optimal procedure must be determined empirically for each sample type. Ideally, the process will result in the complete solubilization, disaggregation, denaturation, and reduction of the proteins in the sample.

When developing a sample preparation strategy, it is important to have a clear idea of what is desired in the final 2-D result. Is the goal to view as many proteins as possible, or is only a subset of the proteins in the sample of potential interest? Which is more important—complete sample representation, or a clear, reproducible pattern? Additional sample preparation steps can improve the quality of the final result, but each additional step can result in the selective loss of protein species. The trade-off between improved sample quality and complete protein representation must therefore be carefully considered.

In order to characterize specific proteins in a complex protein mixture, the proteins of interest must be completely soluble under electrophoresis conditions. Different treatments and conditions are required to solubilize different types of protein samples; some proteins are naturally found in complexes with membranes, nucleic acids, or other proteins, some proteins form various non-specific aggregates, and some proteins precipitate when removed from their normal environment. The effectiveness of solubilization depends on the choice of cell disruption method, protein concentration and dissolution method, choice of detergents, and composition of the sample solution. If any of these steps are not optimized for a particular sample, separations may be incomplete or distorted and information may be lost.

To fully analyze all intracellular proteins, the cells must be effectively disrupted. Choice of disruption method depends on whether the sample is from cells, solid tissue, or other biological material and whether the analysis is targeting all proteins or just a particular subcellular fraction. Both gentle and vigorous lysis methods are discussed in section 1.1.

Proteases may be liberated upon cell disruption. Proteolysis greatly complicates analysis of the 2-D result, thus the protein sample should be protected from proteolysis during cell disruption and subsequent preparation. Protease inhibition is discussed in section 1.2.







If only a subset of the proteins in a tissue or cell type is of interest, prefractionation can be employed during sample preparation. If proteins from one particular subcellular compartment (e.g. nuclei, mitochondria, plasma membrane) are desired, the organelle of interest can be purified by differential centrifugation or other means prior to solubilization of proteins for 2-D electrophoresis. The sample can also be prefractionated by solubility under different extraction conditions prior to 2-D electrophoresis. References 9, 10, 11, and 12 describe examples of this approach. See reference 13 for an overview of protein fractionation techniques.

Precipitation of the proteins in the sample and removal of interfering substances are optional steps. The decision to employ these steps depends on the nature of the sample and the experimental goal. Precipitation procedures, which are used both to concentrate the sample and to separate the proteins from potentially interfering substances, are described in section 1.3. Removal techniques, which eliminate specific contaminants from the sample, are described in section 1.4, as are the effects contaminants (salts, small ionic molecules, ionic detergents, nucleic acids, polysaccharides, lipids, and phenolic compounds) might have on the 2-D result if they are not removed.

In general, it is advisable to keep sample preparation as simple as possible. A sample with low protein concentrations and a high salt concentration, for example, could be diluted normally and analyzed, or desalted, then concentrated by lyophilization, or precipitated with TCA and ice-cold acetone and re-solubilized with rehydration solution. The first option of simply diluting the sample with rehydration solution may be sufficient. If problems with protein concentration or interfering substances are otherwise insurmountable, then precipitation or removal steps may be necessary.

The composition of the sample solution is particularly critical for 2-D because solubilization treatments for the first-dimension separation must not affect the protein pI, nor leave the sample in a highly conductive solution. In general, concentrated urea as well as one or more detergents are used. Sample solution composition is discussed in section 1.5.

General sample preparation guidelines:

-  Keep the sample preparation strategy as simple as possible to avoid protein losses. Additional sample preparation steps may improve the quality of the final 2-D result, but at the possible expense of selective protein loss.
-  The cells or tissue should be disrupted in such a way as to minimize proteolysis and other modes of protein degradation. Cell disruption should be done at as low a temperature as possible and with a minimum of heat generation. Cell disruption should ideally be carried out directly into a strongly denaturing solution containing protease inhibitors.
-  Preserve sample quality by preparing the sample just prior to IEF or storing samples in aliquots at -80 °C. Do not expose samples to repeated thawing.
-  Remove all particulate material by ultracentrifugation. Solid particles and lipids must be removed because they will block the gel pores.
-  To avoid modification of proteins, never heat a sample after adding urea. When the sample contains urea, it must not be heated over 37 °C. Elevated temperatures cause urea to hydrolyze to isocyanate, which modifies proteins by carbamylation.
-  For more specific guidance on preparing samples for application to IPG strips, see references 14–16.

1.1 Methods of cell disruption

Listed in Table 4 and Table 5 are a few standard disruption methods, both mechanical and chemical. Cell disruption should be performed at cold temperatures. Keep the sample on ice as much as possible and use chilled solutions.

Proteases may be liberated upon cell disruption, thus the protein sample should be protected from proteolysis if one of these methods is to be used (see section 1.2). It is generally preferable to disrupt the sample material directly into a strongly denaturing lysis solution, in order to rapidly inactivate proteases and other enzymatic activities that may modify proteins. Cell disruption is often carried out in an appropriate solubilization solution for the proteins of interest. References 17 and 18 contain general information on tissue disruption and cell lysis.

1.1.1 Gentle lysis methods

These methods are generally employed when the sample of interest consists of easily lysed cells (such as tissue culture cells, blood cells, some microorganisms). Gentle lysis methods can also be employed when only one particular subcellular fraction is to be analyzed. For example, conditions can be chosen in which only cytoplasmic proteins are released, or intact mitochondria or other organelles are recovered by differential centrifugation. Sometimes these techniques are combined (e.g. osmotic lysis following enzymatic treatment, freeze-thaw in the presence of detergent).

Table 4. Gentle lysis methods

Cell disruption method	Application	General procedure
<p>Osmotic lysis (19)</p> <p>This very gentle method is well-suited for applications in which the lysate is to be subsequently fractionated into subcellular components.</p>	Blood cells, tissue culture cells	Suspend cells in a hyposmotic solution.
<p>Freeze-thaw lysis (9,17,20)</p> <p>Many types of cells can be lysed by subjecting them to one or more cycles of quick freezing and subsequent thawing.</p>	Bacterial cells, tissue culture cells	Rapidly freeze cell suspension using liquid nitrogen, then thaw. Repeat if necessary.
<p>Detergent lysis</p> <p>Detergents solubilize cellular membranes, lysing cells and liberating their contents.</p>	Tissue culture cells	<p>Suspend cells in lysis solution containing detergent.</p> <p>Cells can often be lysed directly into sample solution or rehydration solution because these solutions always contain detergent. See Appendix 1, solution A for an example of a widely used lysis solution. Further examples of this technique are given in references 21 and 22.</p> <p>If an anionic detergent such as SDS is used for lysis, one of the following preparation steps is required to ensure that the SDS will not interfere with IEF:</p> <ul style="list-style-type: none"> • Dilute the lysed sample into a solution containing an excess of non-ionic or zwitterionic detergent OR, • Separate the SDS from the sample protein by acetone precipitation. <p>(See Table 7 and Table 8, section 1.3 and section 1.5 for details)</p>
<p>Enzymatic lysis (23,24)</p> <p>Cells with cell walls can be lysed gently following enzymatic removal of the cell wall. This must be done with an enzyme specific for the type of cell to be lysed (e.g. lysozyme for bacterial cells, cellulase and pectinase for plant cells, lyticase for yeast cells).</p>	Plant tissue, bacterial cells, fungal cells	Treat cells with enzyme in isoosmotic solution.

1.1.2 More vigorous lysis methods

These methods are employed when cells are less easily disrupted, i.e. cells in solid tissues or cells with tough cell walls. More vigorous lysis methods will result in complete disruption of the cells, but care must be taken to avoid heating or foaming during these procedures.

Table 5. More vigorous lysis methods

Cell disruption method	Application	General procedure
<p>Sonication (5,25,26) Ultrasonic waves generated by a sonicator lyse cells through shear forces. Complete shearing is obtained when maximal agitation is achieved, but care must be taken to minimize heating and foaming.</p>	Cell suspensions	Sonicate cell suspension in short bursts to avoid heating. Cool on ice between bursts.
<p>French pressure cell (23,24,27) Cells are lysed by shear forces resulting from forcing suspension through a small orifice under high pressure.</p>	Microorganisms with cell walls (bacteria, algae, yeasts)	Place cell suspension in chilled French pressure cell. Apply pressure and collect extruded lysate.
<p>Grinding (5,8,28,29) Some cell types can be opened by hand grinding with a mortar and pestle.</p>	Solid tissues, microorganisms	Tissue or cells are normally frozen with liquid nitrogen and ground to a fine powder. Alumina (Al_2O_3) or sand may aid grinding.
<p>Mechanical homogenization (9,19,30–32) Many different devices can be used to mechanically homogenize tissues. Hand-held devices such as Dounce or Potter-Elvehjem homogenizers can be used to disrupt cell suspensions or relatively soft tissues. Blenders, or other motorized devices can be used for larger samples. Homogenization is rapid and poses little danger to proteins except by the proteases that may be liberated upon disruption.</p>	Solid tissues	Chop tissue into small pieces if necessary. Add chilled homogenization buffer (5–20 volumes to volume of tissue). Homogenize briefly. Clarify lysate by filtration and/or centrifugation.
<p>Glass bead homogenization (23,24,33) The abrasive action of the vortexed beads breaks cell walls, liberating the cellular contents.</p>	Cell suspensions, microorganisms	Suspend cells in an equal volume of chilled lysis solution and place into a sturdy tube. Add 1–3 g of chilled glass beads per gram of wet cells. Vortex for 1 min and incubate cells on ice 1 min. Repeat vortexing and chilling two to four times.

1.2 Protection against proteolysis

When cells are lysed, proteases are often liberated or activated. Degradation of proteins through protease action greatly complicates the analysis of 2-D electrophoresis results, so measures should be taken to avoid this problem. If possible, inhibit proteases by disrupting the sample directly into strong denaturants such as 8 M urea, 10% TCA, or 2% SDS (34–38). Proteases are less active at lower temperatures, so sample preparation at as low a temperature as possible is recommended. In addition, proteolysis can often be inhibited by preparing the sample in the presence of tris base, sodium carbonate, or basic carrier ampholyte mixtures.

These approaches alone are often sufficient protection against proteolysis. However, some proteases may retain some activity even under these conditions. In these cases, protease inhibitors may be used. Individual protease inhibitors are only active against specific classes of proteases, so it is usually advisable to use a combination of protease inhibitors. Broad-range protease inhibitor "cocktails" are available from a number of commercial sources. Table 6 lists common protease inhibitors and the proteases they inhibit. For more comprehensive discussions of protease inhibition see references 15, 31, and 39–43.

Table 6. Protease inhibitors

Protease inhibitor	Effective against:	Limitations
PMSF (Phenylmethylsulfonyl fluoride) Most commonly used inhibitor. <i>Use at concentrations up to 1 mM.</i>	PMSF is an irreversible inhibitor that inactivates: <ul style="list-style-type: none"> • serine proteases • some cysteine proteases 	PMSF rapidly becomes inactive in aqueous solutions: Prepare just prior to use. PMSF may be less effective in the presence of thiol reagents such as DTT or 2-mercaptoethanol. This limitation can be overcome by disrupting the sample into PMSF-containing solution lacking thiol reagents. Thiol reagents can be added at a later stage. PMSF is very toxic.
AEBSF (Aminoethyl benzylsulfonyl fluoride or Pefabloc SC Serine Protease Inhibitor) <i>Use at concentrations up to 4 mM.</i>	AEBSF is similar to PMSF in its inhibitory activity, but is more soluble and less toxic.	AEBSF-induced modifications can potentially alter the pI of a protein.
1 mM EDTA or 1 mM EGTA <i>Generally used at 1 mM.</i>	These compounds inhibit metalloproteases by chelating free metal ions required for activity.	
Peptide protease inhibitors (e.g. leupeptin, pepstatin, aprotinin, bestatin) <ul style="list-style-type: none"> • reversible inhibitors • active in the presence of DTT • active at low concentrations under a variety of conditions <i>Use at 2–20 µg/ml.</i>	Leupeptin inhibits many serine and cysteine proteases. Pepstatin inhibits aspartyl proteases (e.g. acidic proteases such as pepsin) Aprotinin inhibits many serine proteases. Bestatin inhibits aminopeptidases.	Peptide protease inhibitors are: <ul style="list-style-type: none"> • expensive. • small peptides and thus may appear on the 2-D map, depending on the size range separated by the second-dimension gel. Pepstatin does not inhibit any proteases that are active at pH 9.
TLCK, TPCK (Tosyl lysine chloromethyl ketone, tosyl phenylalanine chloromethyl ketone) <i>Use at 0.1–0.5 mM.</i>	These similar compounds irreversibly inhibit many serine and cysteine proteases.	
Benzamidine <i>Use at 1–3 mM.</i>	Benzamidine inhibits serine proteases.	

1.3 Precipitation procedures

Protein precipitation is an optional step in sample preparation for 2-D electrophoresis. Precipitation, followed by resuspension in sample solution, is generally employed to selectively separate proteins in the sample from contaminating species such as salts, detergents, nucleic acids, lipids, etc., that would otherwise interfere with the 2-D result. Precipitation followed by resuspension can also be employed to prepare a concentrated protein sample from a dilute source (e.g. plant tissues, urine).

Table 7. Precipitation procedures

Precipitation method	General procedure	Limitations
<p>Ammonium sulfate precipitation ("Salting out") In the presence of high salt concentrations, proteins tend to aggregate and precipitate out of solution. Many potential contaminants (e.g. nucleic acids) will remain in solution.</p>	<p>Prepare protein so final concentration of the protein solution is >1 mg/ml in a buffer solution that is >50 mM and contains EDTA. Slowly add ammonium sulfate to the desired percent saturation (44) and stir for 10–30 min. Pellet proteins by centrifugation.</p>	<p>Many proteins remain soluble at high salt concentrations, so this method is not recommended when total protein representation is desired. This method can, however, be used for prefractionation or enrichment. Residual ammonium sulfate will interfere with IEF and must be removed (45). See section 1.4 on removal of salts.</p>
<p>TCA precipitation TCA (trichloroacetic acid) is a very effective protein precipitant.</p>	<p>TCA is added to the extract to a final concentration of 10–20% and the proteins are allowed to precipitate on ice for 30 min (46). Alternatively, tissue may be homogenized directly into 10–20% TCA (35,47). This approach limits proteolysis and other protein modifications. Centrifuge and wash pellet with acetone or ethanol to remove residual TCA.</p>	<p>Proteins may be difficult to resolubilize and may not resolubilize completely. Residual TCA must be removed by extensive washing with acetone or ethanol. Extended exposure to this low pH solution may cause some protein degradation or modification.</p>
<p>Acetone precipitation This organic solvent is commonly used to precipitate proteins. Many organic-soluble contaminants (e.g. detergents, lipids) will remain in solution.</p>	<p>Add at least 3 volumes of ice-cold acetone to the extract. Allow proteins to precipitate at -20 °C for at least 2 h. Pellet proteins by centrifugation (46,48–50). Residual acetone is removed by air drying or lyophilization.</p>	
<p>Precipitation with TCA in acetone The combination of TCA and acetone is commonly used to precipitate proteins during sample preparation for 2-D electrophoresis, and is more effective than either TCA or acetone alone.</p>	<p>Suspend lysed or disrupted sample in 10% TCA in acetone with either 0.07% 2-mercaptoethanol or 20 mM DTT. Precipitate proteins for at least 45 min at -20 °C. Pellet proteins by centrifugation and wash pellet with cold acetone containing either 0.07% 2-mercaptoethanol or 20 mM DTT. Remove residual acetone by air drying or lyophilization (5,28,34,43,51,52).</p>	<p>Proteins may be difficult to resolubilize and may not resolubilize completely. Extended exposure to this low pH solution may cause some protein degradation or modification.</p>
<p>Precipitation with ammonium acetate in methanol following phenol extraction This technique has proven useful with plant samples containing high levels of interfering substances.</p>	<p>Proteins in the sample are extracted into water- or buffer-saturated phenol. Proteins are precipitated from the phenol phase with 0.1 M ammonium acetate in methanol. The pellet is washed several times with ammonium acetate in methanol and then with acetone. Residual acetone is evaporated (42,43,47,53).</p>	<p>The method is complicated and time consuming.</p>

No precipitation technique is completely efficient and some proteins may not readily resuspend following precipitation. Thus, employing a precipitation step during sample preparation can alter the protein profile of a sample. Precipitation and resuspension should be avoided if the aim of a 2-D experiment is complete and accurate representation of all the proteins in a sample. Table 7 lists some of the precipitation techniques used. If sample preparation requires precipitation, typically only one precipitation technique is employed.

For an overview of precipitation techniques see references 17, 18, and 44.

1.4 Removal of contaminants that affect 2-D results

Non-protein impurities in the sample can interfere with separation and subsequent visualization of the 2-D result, so sample preparation can include steps to rid the sample of these substances. Table 8 lists contaminants that affect 2-D results and techniques for their removal. Reference 15 provides further discussion on the removal of interfering substances.



Salt contamination is the most frequent cause of insufficient focusing of protein spots!

Table 8. Contaminants that affect 2-D results

Contaminant	Reason for removal	Removal techniques
Salts, residual buffers, and other charged small molecules that carry over from sample preparation.	Salts disturb the electrophoresis process and must be removed or maintained at as low a concentration as possible. Salts in the IPG strip result in high strip conductivity. Focusing of the proteins will not occur until the ions have moved to the ends of the strips, prolonging the time required for IEF. Water movement can also result, causing one end of the strip to dry out and the other to swell. Salt in the IPG strip can result in large regions at either end of the IPG strip where proteins do not focus (seen as horizontal streaking or empty regions in the final result). If the sample is rehydrated into the IPG strip, the salt concentration in the rehydration solution should be lower than 10 mM. If the sample is applied in sample cups, salt concentrations of up to 50 mM in the sample may be tolerated, however proteins may precipitate at the sample application point as they abruptly move into a lower salt environment.	Desalting can be performed by <ul style="list-style-type: none"> • dialysis • spin dialysis • gel filtration • precipitation/resuspension Dialysis is a very effective method for salt removal resulting in minimal sample loss, however, the process is time consuming and requires large volumes of solution. Spin dialysis is quicker, but protein adsorption onto the dialysis membrane may be a problem. Spin dialysis should be applied to samples prior to addition of urea and detergent. Gel filtration can be acceptable but often results in protein losses. Precipitation/resuspension is an effective means for removing salts and other contaminants, but can also result in losses (see section 1.3).
Endogenous small ionic molecules, (nucleotides, metabolites, phospholipids, etc).	Endogenous small ionic molecules are present in any cell lysate. These substances are often negatively charged and can result in poor focusing towards the anode.	TCA/acetone precipitation is particularly effective at removing this sort of contaminant. Other desalting techniques may be applied (see above).

continues on following page

Table 8. Contaminants that affect 2-D results (continued)

Contaminant	Reason for removal	Removal techniques
Ionic detergent	Ionic detergent (usually SDS) is often used during protein extraction and solubilization, but can strongly interfere with IEF. SDS forms complexes with proteins, and the resulting negatively charged complex will not focus unless the SDS is removed or sequestered.	Dilute the SDS-containing sample into a rehydration solution containing a zwitterionic or non-ionic detergent (CHAPS, Triton X-100™, or NP-40) so the final concentration of SDS is 0.25% or lower and the ratio of the other detergent to SDS is at least 8:1 (27). Acetone precipitation of the protein will partially remove SDS. Precipitation at room temperature will maximize removal of SDS, but protein precipitation is more complete at -20 °C (45).
Nucleic acids (DNA, RNA)	Nucleic acids increase sample viscosity and cause background smears. High-molecular weight nucleic acids can clog gel pores. Nucleic acids can bind to proteins through electrostatic interactions, preventing focusing. If the separated sample proteins are visualized by silver staining, nucleic acids present in the gel will also stain, resulting in a background smear on the 2-D gel.	Treat samples rich in nucleic acids with a protease-free DNase/RNase mixture to reduce the nucleic acids to mono- and oligonucleotides. This is often done by adding 0.1 × volume of a solution containing 1 mg/ml DNase I, 0.25 mg/ml RNase A, and 50 mM MgCl ₂ followed by incubation on ice (33,50). <i>Note: The proteins DNase and RNase may appear on the 2-D map.</i> Ultracentrifugation can be used to remove large nucleic acids, however, this technique may also remove high-molecular weight proteins from the sample. When using low-ionic strength extraction conditions, negatively charged nucleic acids may form complexes with positively charged proteins. High-ionic strength extraction and/or high-pH extraction may minimize these interactions. (Note that salts added during extraction must be subsequently removed, see above).
Polysaccharides	Polysaccharides can clog gel pores causing either precipitation or extended focusing times, resulting in horizontal streaking. Some polysaccharides contain negative charges and can complex with proteins by electrostatic interactions.	Precipitate the sample in TCA, ammonium sulfate, or phenol/ammonium acetate, then centrifuge. Ultracentrifugation will remove high-molecular weight polysaccharides. Employing the same methods used for preventing protein-nucleic acid interactions may also be helpful (solubilize sample in SDS or at high pH).
Lipids	Many proteins, particularly membrane proteins, are complexed with lipids. This reduces their solubility and can affect both the pI and the molecular weight. Lipids form complexes with detergents, reducing the effectiveness of the detergent as a protein-solubilizing agent. When extracts of lipid-rich tissues are centrifuged, there is often a lipid layer that can be difficult to remove.	Strongly denaturing conditions and detergents minimize protein-lipid interactions. Excess detergent may be necessary. Precipitation with acetone removes some lipid.

continues on following page

Table 8. Contaminants that affect 2-D results (continued)

Contaminant	Reason for removal	Removal techniques
Phenolic compounds	Phenolic compounds are present in many plant tissues and can modify proteins through an enzyme-catalyzed oxidative reaction (43,49).	Prevent phenolic oxidation by employing reductants during tissue extraction (e.g. DTT, 2-mercaptoethanol, sulfite, ascorbate). Rapidly separate proteins from phenolic compounds by precipitation techniques. Inactivate polyphenol oxidase with inhibitors such as diethyldithiocarbamic acid or thiourea. Remove phenolic compounds by adsorption to polyvinylpyrrolidone (PVP) or polyvinylpolypyrrolidone (PVPP).
Insoluble material	Insoluble material in the sample can clog gel pores and result in poor focusing. Insoluble material is particularly problematic when the sample is applied using sample cups; it can prevent protein entry into the IPG strip.	Samples should always be clarified by centrifugation prior to application to first-dimension IEF.

1.5 Composition of sample solution

In order to achieve a well-focused first-dimension separation, sample proteins must be completely disaggregated and fully solubilized. Regardless of whether the sample is a relatively crude lysate or additional sample precipitation steps have been employed, the sample solution must contain certain components to ensure complete solubilization and denaturation prior to first-dimension IEF. These always include urea and one or more detergents. Complete denaturation ensures that each protein is present in only one configuration, and that aggregation and intermolecular interaction is avoided. The lysis solution, solution A (see Appendix I, page 83), which contains urea and the zwitterionic detergent CHAPS, has been found to be effective for solubilizing a wide range of samples. Reductant and IPG Buffer are also frequently added to the sample solution to enhance sample solubility.

IEF performed under denaturing conditions gives the highest resolution and the cleanest results. Urea, a neutral chaotrope, is used as the denaturant in the first-dimension of 2-D electrophoresis. It is always included in the 2-D sample solution at a concentration of at least 8 M. Urea solubilizes and unfolds most proteins to their fully random conformation, with all ionizable groups exposed to solution. Recently, the use of thiourea in addition to urea has been found to further improve solubilization, particularly of membrane proteins (10,16,54–56).

A non-ionic or zwitterionic detergent is always included in the sample solution to ensure complete sample solubilization and to prevent aggregation through hydrophobic interactions. Originally, either of two similar non-ionic detergents, NP-40 or Triton X-100, was used (1,2). Subsequent studies have demonstrated that the zwitterionic detergent CHAPS is often more effective (57). New zwitterionic detergents have been developed and reported to improve the solubility of membrane proteins (58,59).

When difficulties in achieving full sample solubilization are encountered, the anionic detergent SDS can be used as a solubilizing agent. SDS is a very effective protein solubilizer, but because it is charged and forms complexes with proteins, it cannot be used as the sole detergent for solubilizing samples for 2-D electrophoresis. A widely used method for negating the interfering effect of SDS is dilution of the sample into a solution containing an excess of CHAPS, Triton X-100, or NP-40. The final concentration of SDS should be 0.25% or lower and the ratio of the excess detergent to SDS should be at least 8:1 (27,34,60).

Reducing agents are frequently included in the sample solution to break any disulfide bonds present and to maintain all proteins in their fully reduced state. The most commonly used reductant is dithiothreitol (DTT) at concentrations ranging from 20 to 100 mM. Dithioerythreitol (DTE) is similar to DTT and can also be used as a reducing agent. Originally, 2-mercaptoethanol was used as a reductant, but higher concentrations of the reductant are required and inherent impurities may result in artifacts (61). More recently, the non-thiol reductant tributyl phosphine (TBP), at a concentration of 2 mM, has been used as a reductant for 2-D samples (62). However, due to the limited solubility and instability of TBP in solution, a thiol reductant such as DTT should be used to maintain proteins in their reduced state through rehydration and first-dimension IEF, if TBP is employed as a reductant during sample preparation.

Carrier ampholytes or IPG Buffer (up to 2% (v/v)) can be included in the sample solution. They enhance protein solubility by minimizing protein aggregation due to charge-charge interactions. In some cases, buffers or bases (e.g. 40 mM Tris base) are added to the sample solution. This is done when basic conditions are required for full solubilization or to minimize proteolysis. However, introduction of such ionic compounds can result in first-dimension disturbances. Bases or buffers should be diluted to 5 mM or lower prior to loading the sample onto first-dimension IEF.

A sample should remain in sample solution at room temperature for at least 30 min for full denaturation and solubilization prior to centrifugation and subsequent sample application. Heating of the sample in the presence of detergent can aid in solubilization, but should only be done prior to the addition of urea. Sonication helps speed up solubilization, particularly from material that is otherwise difficult to resuspend.

A widely used sample solution is given in Appendix I, solution A. For a general review of protein solubilization for electrophoretic analysis, see reference 15.



For the first experiments with an unknown sample the following, most frequently employed, default sample solutions are proposed:

Dissolve proteins in:

- 8 M urea, 4% CHAPS, 60 mM DTT, 2% Pharmalyte™ 3–10, 0.002% bromophenol blue.
To solubilize large and more hydrophobic proteins the following procedure is recommended:
- 7 M urea, 2 M thiourea, 4% CHAPS, 60 mM DTT, 2% Pharmalyte pH 3–10, 0.002% bromophenol blue.

To prepare proteins from tissues that are dilute sources of protein and contain high levels of interfering substances (e.g. plant tissues) the following procedure is recommended. This method produces protein solutions substantially free of salts, nucleic acids, and other contaminants:

- Grind tissue in mortar and pestle with liquid nitrogen. Suspend powder in 10% TCA, 0.3% DTT in acetone. Keep at -18 °C overnight and centrifuge. Wash pellet with acetone. Dry and resuspend in 9 M urea, 2% CHAPS, 1% DTT, 2% Pharmalyte 3–10 (52,63).

New kits for mild protein precipitation, quick dialysis without protein loss, and non-interfering protein assays, have been introduced by Amersham Biosciences.

For appropriate sample loads see Table 12 on page 36.

Chapter 2

First-dimension Isoelectric Focusing (IEF)

2.0 First-dimension isoelectric focusing—overview

Amersham Biosciences offers two different systems for the first-dimension separation; the Multiphor II system with associated accessories and the Ettan IPGphor Isoelectric Focusing System. For a comparison of these two systems, see page 12.

A useful first-dimension separation requires selecting a first-dimension pH range appropriate for the sample, as well as a suitable sample application method. Choice of immobilized pH gradient is discussed in section 2.2. Sample application methods and their selection are discussed in section 2.3.

The first-dimension separation procedure involves IPG strip rehydration, sample application, and isoelectric focusing. Preparation of the IPG strip rehydration solution is described in section 2.4. The protocols for IPG strip rehydration, sample application, and IEF are specific to the first-dimension system used and are described in section 2.5 for the Multiphor II system, and section 2.6 for the IPGphor Isoelectric Focusing System.

2.1 Background to isoelectric focusing (IEF)

IEF is an electrophoretic method that separates proteins according to their isoelectric points (pI). Proteins are amphoteric molecules; they carry either positive, negative, or zero net charge, depending on the pH of their surroundings (Fig 8). The net charge of a protein is the sum of all the negative and positive charges of its amino acid side chains and amino- and carboxyl-termini. The isoelectric point (pI) is the specific pH at which the net charge of the protein is zero. Proteins are positively charged at pH values below their pI and negatively charged at pH values above their pI. If the net charge of a protein is plotted versus the pH of its environment, the resulting curve intersects the x-axis at the isoelectric point (Fig 8).

The presence of a pH gradient is critical to the IEF technique. In a pH gradient, under the influence of an electric field, a protein will move to the position in the gradient where its net charge is zero. A protein with a positive net charge will migrate toward the cathode, becoming progressively less positively charged as it moves through the pH gradient until it reaches its pI. A protein with a negative net charge will migrate toward the anode, becoming less negatively charged until it also reaches zero net charge. If a protein should diffuse away from its pI, it immediately gains charge and migrates back. This is the *focusing* effect of IEF, which concentrates proteins at their pIs and allows proteins to be separated on the basis of very small charge differences.

The resolution is determined by the slope of the pH gradient and the electric field strength. IEF is therefore performed at high voltages (typically in excess of 1 000 V). When the proteins have reached their final positions in the pH gradient, there is very little ionic movement in the system, resulting in a very low final current (typically below 1 mA). IEF of a given sample in a given electrophoresis system is generally performed for a constant number of Volt-hours (Volt-hour (Vh) being the integral of the volts applied over the time).

IEF performed under denaturing conditions gives the highest resolution and the cleanest results. Complete denaturation and solubilization is achieved with a mixture of urea and detergent, ensuring that each protein is present in only one configuration and aggregation and intermolecular interaction is minimized.

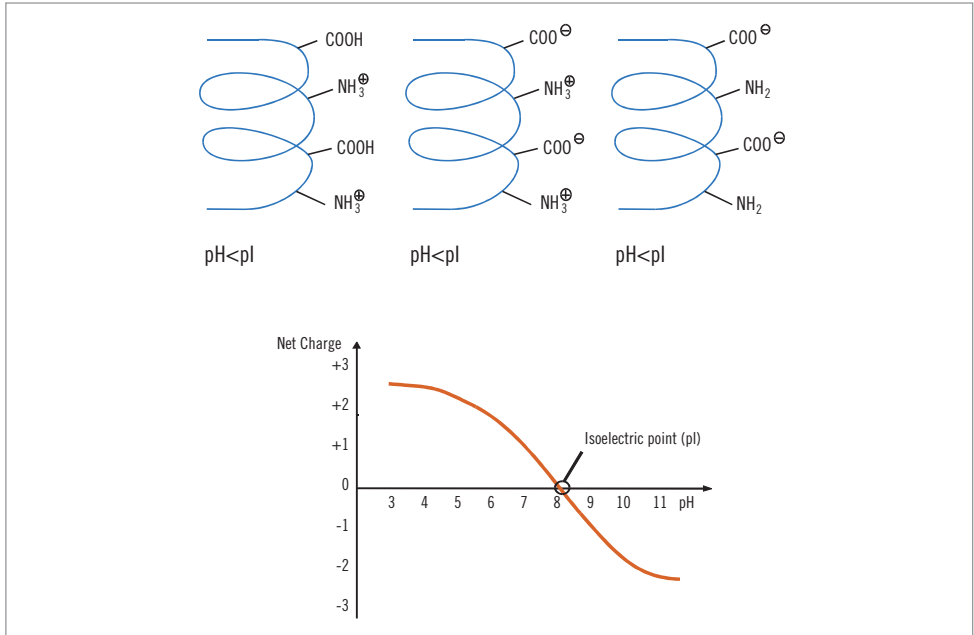

Fig 8. Plot of the net charge of a protein versus the pH of its environment. The point of intersection of the curve at the x-axis represents the isoelectric point of the protein.

The original method for first-dimension IEF depended on carrier ampholyte-generated pH gradients in polyacrylamide gel rods in tubes (1,2). Carrier ampholytes are small, soluble, amphoteric molecules with a high buffering capacity near their pI. Commercial carrier ampholyte mixtures are comprised of hundreds of individual polymeric species with pIs spanning a specific pH range. When a voltage is applied across a carrier ampholyte mixture, the carrier ampholytes with the highest pI (and the most negative charge) move toward the anode and the carrier ampholytes with the lowest pI (and the most positive charge) move toward the cathode. The other carrier ampholytes align themselves between the extremes, according to their pIs, and buffer their environment to the corresponding pHs. The result is a continuous pH gradient.

Although this basic method has been used in hundreds of 2-D electrophoresis studies, it has several limitations that have prevented its more widespread application:

- Carrier ampholytes are mixed polymers that are not well characterized and suffer from batch-to-batch manufacturing variations. These variations reduce the reproducibility of the first-dimension separation.
- Carrier ampholyte pH gradients are unstable and have a tendency to drift, usually toward the cathode, over time. Gradient drift adversely affects reproducibility by introducing a time variable. Gradient drift also causes a flattening of the pH gradient at each end, particularly above pH 9, rendering the 2-D technique less useful at pH extremes.

- The soft polyacrylamide tube gels have low mechanical stability. The gel rods may stretch or break, affecting reproducibility. Results are often dependent on the skill of the operator.

As a result of the limitations and problems with carrier ampholyte pH gradients, immobilized pH gradients were developed and Amersham Biosciences's Immobiline chemicals were introduced for the generation of this type of pH gradient (3). Görg *et al.* (4,5) pioneered the development and use of IPG IEF for the first-dimension of 2-D electrophoresis. The techniques used today are largely based on the work of A. Görg and her colleagues.

An immobilized pH gradient (IPG) is created by covalently incorporating a gradient of acidic and basic buffering groups into a polyacrylamide gel at the time it is cast. The buffers, Amersham Biosciences Immobiline reagents, are a set of well-characterized molecules, each with a single acidic or basic buffering group linked to an acrylamide monomer.

The general structure of Immobiline reagents is:

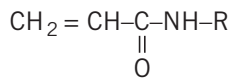

R = weakly acidic or basic buffering group.

Immobilized pH gradients are formed using two solutions, one containing a relatively acidic mixture of acrylamido buffers and the other containing a relatively basic mixture. The concentrations of the various buffers in the two solutions define the range and shape of the pH gradient produced. Both solutions contain acrylamide monomers and catalysts. During polymerization, the acrylamide portion of the buffers copolymerize with the acrylamide and bisacrylamide monomers to form a polyacrylamide gel. Figure 9 is a graphic representation of the polyacrylamide matrix with attached buffering groups.

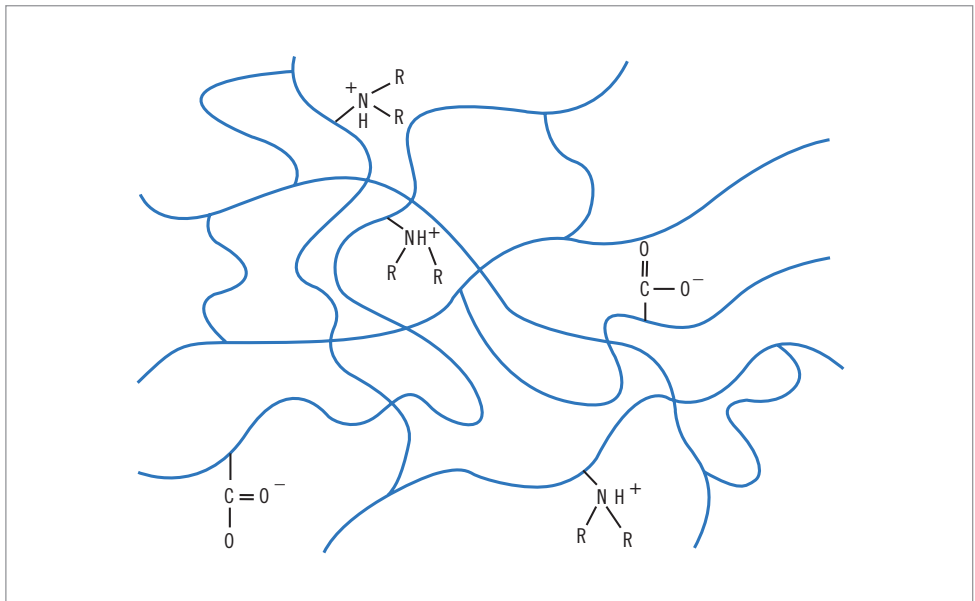

Fig 9. Immobilized pH gradient polyacrylamide gel matrix showing attached buffering groups.

For improved performance and simplified handling, the IPG gel is cast onto a plastic backing. The gel is then washed to remove catalysts and unpolymerized monomers, which could otherwise modify proteins and interfere with separation. Finally the gel is dried and cut into 3 mm-wide strips. The resulting IPG strips can be rehydrated with a rehydration solution containing the necessary components for first-dimension IEF.

IEF is performed with the IPG strips placed horizontally on a flatbed electrophoresis unit. Advantages of using the flatbed format include the following:

- Isoelectric focusing requires efficient cooling for close temperature control, which can be effectively achieved on a horizontal ceramic cooling plate connected to a thermostatic circulator or a Peltier cooling plate.
- IEF requires high field strengths to obtain sharply focused bands, thus high voltages must be applied. A flatbed design is the most economical way to meet the necessary safety standards required to operate at such high voltages.

The IPG strips are rehydrated in a solution containing the necessary additives and, optionally, the sample proteins. (Rehydration solution is described in detail in section 2.4, page 33). IEF is performed by gradually increasing the voltage across the IPG strips to at least 3 500 V and maintaining this voltage for at least several thousand Volt-hours. After IEF, the IPG strips are equilibrated in equilibration solution and applied onto flatbed or vertical SDS-polyacrylamide gels.

When IPG strips are used for the first-dimension separation, the resultant 2-D maps are superior in terms of resolution and reproducibility. IPG strips are a marked improvement over tube gels with carrier ampholyte-generated pH gradients:

- The first-dimension separation is more reproducible because the covalently fixed gradient cannot drift.
- Plastic-backed IPG strips are easy to handle. They can be picked up at either end with forceps or gloved fingers.
- The plastic support film prevents the gels from stretching or breaking.
- IPG technology increases the useful pH range on any single IPG strip; more very acidic and basic proteins can be separated.
- IPG strips have a higher loading capacity for protein (64).
- The sample can be introduced into the IPG strip during rehydration (65,66).
- Precast Immobiline DryStrip gels are available from Amersham Biosciences. These ready-made dry IPG strips eliminate the need to handle toxic acrylamide monomers, preparation time and effort are significantly reduced, and reproducibility of the pH gradient is assured.

2.2 Immobilized pH gradient selection

Ready-made IPG strips, Immobiline DryStrip gels, are available from Amersham Biosciences with strip lengths of 7, 11, 13, 18, and 24 cm. Choose shorter strips for fast screening or when the most abundant proteins are of interest. Use longer strips for maximal resolution and loading capacity.

Choosing the pH Gradient



Use a pH interval of 3–10 for an overview of total protein distribution. With a linear gradient pH 3–10 the estimation of protein's isoelectric point pI is relatively easy.



For increased resolution between pH 5 and 7, use 3–10 NL (Non Linear) to distribute the proteins more evenly over the gel. This is especially helpful when analyzing complex samples like serum, cerebrospinal fluid, extracts from *E.coli*, and yeast.



Combine pH 3–7 and 6–11 (or pH 4–7 and 6–9) to obtain a more detailed overview of the protein distribution.



For studying the protein pattern in more detail with the highest resolution and sample load, narrow pH gradients in 18 and 24 cm strips offered for extremely high resolution are available: pH 3.5–4.5, 4–5, 4.5–5.5, 5–6, and 5.5–6.7.

Note: The gradients overlap to enable the assembly of virtual high-resolution 2-D maps from different narrow-range separations.

If a specialized pH gradient is required, recipes for preparing custom narrow and wide immobilized pH gradients are given in (67).

2.3 Sample application method selection

Sample can be applied either by including it in the rehydration solution (rehydration loading) or by applying it directly to the rehydrated IPG strip via sample cups, sample wells, or paper bridge. Usually rehydration loading is preferable (see section 2.4). Advantages to this mode of application include the following:

- Rehydration loading allows larger quantities of protein to be loaded and separated (65,66).
- Rehydration loading allows more dilute samples to be loaded.
- Because there is no discrete application point, this method eliminates the formation of precipitates at the application point that often occur when loading with sample cups.
- The rehydration loading method is technically simpler, avoiding problems of leakage that can occur when using sample cups.
- There are, however, cases when one might prefer to load the sample following rehydration, immediately prior to IEF, e.g. if proteolysis or other protein modifications are a concern, overnight rehydration with sample may not be desired.



Better results are obtained on pH 6–11 or 6–9 IPG strips when the sample is loaded anodically in a sample cup!

The following two diagrams represent a general rule of how to select the appropriate mode of sample application:

Multiphor II system

pH gradient	Analytical		Preparative
3.5–4.5			
4.0–5.0			
4.5–5.5			
5.0–6.0			
5.5–6.7	rehydration loading	cup loading	rehydration loading
4–7, 3–7			
3–10			
3–10 NL			
6–9			paper bridge
6–11			

Guidelines for sample application after rehydration using the Multiphor II and Immobiline DryStrip Kit system are given on page 34.

For cup loading, sample is pipetted into sample cups precisely positioned on the surface of the IPG gels. Up to 100 µl per strip can be applied through the sample cups, up to 850 µl with paper-bridge loading (68).

Ettan IPGphor Isoelectric Focusing System

pH gradient	Analytical		Preparative
	Strip Holder	Cup Loading Strip Holder	Cup Loading Strip Holder
3.5–4.5			
4.0–5.0			
4.5–5.5			
5.0–6.0			
5.5–6.7	rehydration loading	rehydration loading	rehydration loading
4–7, 3–7			
3–10			
3–10 NL			
6–9			paper bridge
6–11			

Ettan IPGphor system guidelines for sample application after rehydration are given in section 2.6.3, page 51. Sample is pipetted into sample application wells located at each end of the Strip Holder. Up to 7.5 µl of sample solution can be added to each side (i.e. 15 µl per well or 30 µl total if both sides of both wells are used). Up to 100 µl per strip can be applied through the sample cups when Ettan IPGphor Cup Loading Strip Holder is employed. Furthermore, rehydration loading and cup loading can be combined for the application of larger volumes. Paper-bridge loading can be performed in the Ettan IPGphor Cup Loading Strip Holder as well. Up to 500 µl can be applied using the paper bridge method.

2.4 IPG strip rehydration solution

IPG strips must be rehydrated prior to IEF. The IPG strips are rehydrated in the Immobiline DryStrip Reswelling Tray if either Multiphor II system or the Ettan IPGphor Cup Loading Strip Holder are used for IEF. Using the Ettan IPGphor and the Strip Holder, the strips are rehydrated in these strip holders.

Rehydration solution, which may or may not include the sample, is applied to the reservoir slots of the Reswelling Tray or Ettan IPGphor Strip Holder, then the IPG strips are soaked individually. Rehydrated strips are 3 mm wide and approximately 0.5 mm thick.



Note: Cup Loading Strip Holder cannot be used for rehydration.

2.4.1 Components of the rehydration solution

The choice of the most appropriate rehydration solution for the sample will depend on its specific protein solubility requirements, but a typical solution generally contains urea, non-ionic or zwitterionic detergent, dithiothreitol (DTT), Pharmalytes, or IPG Buffer (Amersham Biosciences) appropriate to the pH range of the IPG strip and dye. The sample may also be included. The role of each component is described below, as well as the recommended concentration range.



Urea solubilizes and denatures proteins, unfolding them to expose internal ionizable amino acids. Commonly 8 M urea is used, but the concentration can be increased to 9 or 9.8 M if necessary for complete sample solubilization. **Thiourea**, in addition to urea, can be used to further improve protein solubilization (10,16,54–56).



Detergent solubilizes hydrophobic proteins and minimizes protein aggregation. The detergent must have zero net charge—use only non-ionic and zwitterionic detergents. CHAPS, Triton X-100, or NP-40 in the range of 0.5 to 4% are most commonly used.



Reductant cleaves disulfide bonds to allow proteins to unfold completely. DTT or DTE (20 to 100 mM) are commonly used. 2-Mercaptoethanol is not recommended, because higher concentrations are required, and impurities may result in artifacts (61). Tributyl phosphine (TBP) is not recommended as reductant for IEF due to its low solubility and poor stability in rehydration solution. Reductants should be added directly before use.



IPG Buffer or Pharmalyte (carrier ampholyte mixtures) improve separations, particularly with high sample loads. Carrier ampholyte mixtures enhance protein solubility and produce more uniform conductivity across the pH gradient without disturbing IEF or affecting the shape of the gradient.

IPG Buffers are carrier ampholyte mixtures specially formulated not to interfere with silver staining following 2-D electrophoresis. Select an IPG buffer with the sample pH interval as the Immobiline DryStrip to be rehydrated. Use IPG Buffer 3.5–5.0 for Immobiline DryStrip 3.5–4.5 and 4.0–5.0. Use IPG Buffer 6–11 for Immobiline DryStrip 6–9 and 6–11. Pharmalyte 3–10 may be used for separations on Immobiline DryStrip pH 3–10 and 3–10 NL. Pharmalyte 5–8 may be used for separations on Immobiline DryStrip pH 4–7.

Table 9 lists the recommended final concentration of IPG Buffer / Pharmalyte for the rehydration solution. The recommended IPG Buffer / Pharmalyte concentration for the IPGphor system is 0.5%, but up to 2% can be added if sample solubilization remains a problem.

Table 9. Addition of IPG Buffer or Pharmalyte to rehydration solution

IEF system	Sample application mode(s)	Second-dimension system	Recommended concentration
Multiphor II	Cup-, rehydration-, and paper-bridge loading	Vertical gels, flatbed	2% IPG Buffer (50 µl per 2.5 ml) 0.5% IPG Buffer (12.5 µl per 2.5 ml)
Etan IPGphor			
Strip Holder	Rehydration and sample-well loading	Vertical gels, flatbed	0.5% IPG Buffer (12.5 µl per 2.5 ml) 0.5% IPG Buffer (12.5 µl per 2.5 ml)
Cup Loading Strip Holder	Cup- and paper-bridge loading	Vertical gels, flatbed	2% IPG Buffer (50 µl per 2.5 ml) 0.5% IPG Buffer (12.5 µl per 2.5 ml)

The advantages of increased concentration of IPG Buffer / Pharmalyte are:

- Improved sample solubilization
- Increased tolerance to salt in sample
- A more even conductivity in the gel

The drawbacks of increased concentration of IPG Buffer / Pharmalyte are:

- Higher concentrations will limit the voltage use during IEF and increase the time required for the focusing step.
- Silver staining may require a prolonged fixing step to wash out carrier ampholyte that may cause staining background.

IPG Buffer or Pharmalyte can be included in the stock rehydration solution or added just prior to use. (The carrier ampholytes are included in the stock solution when multiple IPG strips of the same pH range are to be used. Carrier ampholytes are added to single aliquots of the stock solution when the same stock solution will be used with different pH range IPG strips). See section 2.4.2.



Tracking dye (bromophenol blue) allows IEF progress to be monitored at the beginning of the protocol. If the tracking dye does not migrate toward the anode, no current is flowing. Note: the dye leaves the strip well before the sample is focused!



Sample can be applied by including it in the rehydration solution. Up to 1 mg of sample per strip can be diluted or dissolved in rehydration solution prior to IEF. The amount of sample required is dictated in part by the detection or visualization method used. Radiolabelling requires a very small amount of sample, silver staining requires typically 1 to 100 µg of sample, and Coomassie™ blue staining and preparative applications require larger sample amounts.

2.4.2 Rehydration solution preparation

Typical composition of rehydration solution without sample, or for dilution with sample solution:

8 M urea, 0.5% (w/v) CHAPS, 0.2% (w/v) DTT, 0.5% (v/v) IPG Buffer or Pharmalyte, 0.002% bromophenol blue.

1. Prepare the rehydration stock solution. Recommended formulations are listed in Appendix I, solutions B, C, and D (select the formulation appropriate to the experiment).

Note: Stock solution can be stored in 2.5 ml aliquots at -20 °C.

2. Just prior to use, slowly thaw a 2.5 ml aliquot of stock solution. Add the appropriate amount of IPG Buffer or Pharmalyte, if it is not already included in the rehydration stock solution (refer to Table 9).
3. Add 7 mg DTT and sample (if rehydration loading is desired, refer to Table 11).

Note: DTT and the sample must be added fresh, just prior to use.

2.5 Multiphor II and Immobiline DryStrip Kit

2.5.1 IPG strip rehydration—Immobiline DryStrip Reswelling Tray

The Immobiline DryStrip Reswelling Tray has twelve independent reservoir slots that can each hold a single IPG strip up to 24 cm long. Separate slots allow the rehydration of individual IPG strips in a minimal volume of solution.

1. Prepare the Reswelling Tray (Fig 10)

Slide the protective lid completely off the tray and level the tray by turning the leveling feet until the bubble in the spirit level is centered. Ensure the tray is clean and dry.

2. Apply the rehydration solution

Prepare the rehydration solution, including sample for rehydration loading or without sample for cup application. Pipette the appropriate volume of rehydration solution into each slot as indicated in Table 10. Deliver the solution slowly at a central point in the slot. Remove any larger bubbles.

Important: To ensure complete fluid (and sample) uptake, do not apply excess rehydration solution.

3. Position the IPG strip (Fig 11)

Remove the protective cover from the IPG strip starting at the acidic (pointed) end. Removal from the acidic (pointed) end prevents damage to the basic (square) end of the IPG strip, which is generally softer. Position the IPG strip as shown in Figure 11, with the gel side down and the pointed end of the strip against the sloped end of the slot. Lower the IPG strip onto the solution. To help coat the entire IPG strip, gently lift and lower the strip and slide it back and forth along the surface of the solution. Be careful not to trap bubbles under the IPG strip.

Table 10. Rehydration solution volume per IPG Strip

IPG strip length (cm)	Total volume per strip* (µl)
7 cm	125 µl
11 cm	200 µl
13 cm	250 µl
18 cm	340 µl
24 cm	450 µl

*Including sample, if applied.

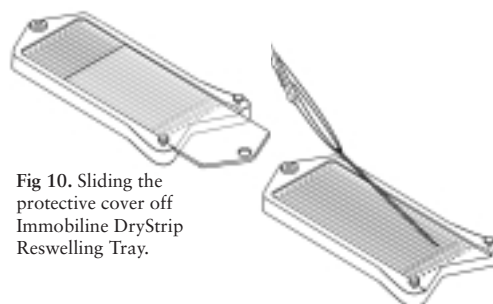

Fig 10. Sliding the protective cover off Immobiline DryStrip Reswelling Tray.

Fig 11. Positioning of an IPG strip on Immobiline DryStrip Reswelling Tray.

4. Overlay the IPG strip with DryStrip Cover Fluid

Overlay each IPG strip with 3 ml of DryStrip Cover Fluid to minimize evaporation and urea crystallization.

5. Allow the IPG strip to rehydrate

Slide the lid onto the Reswelling Tray and allow the IPG strips to rehydrate at room temperature. A minimum of 10 h is required for rehydration; overnight is recommended. If the IPG strips swell unevenly, refer to Table 12.

6. Prepare the Immobiline DryStrip Kit

Before removing the IPG strips from the Reswelling Tray, prepare the Immobiline DryStrip Kit and the electrode strips as described in section 2.5.2.A and 2.5.2.B.

Table 11. Suitable sample loads* for silver and Coomassie staining using cup loading and rehydration loading

Immobiline DryStrip (pH)	Suitable sample load (μg of protein)		
	Silver stain	Coomassie stain	
7 cm	4–7	4–8	20–120
	6–11	8–16	40–240
	3–10, 3–10 NL	2–4	10–60
11 cm	4–7	10–20	50–300
	6–11	20–40	100–600
	3–10 L	4–8	20–120
13 cm	4–7	15–30	75–450
	6–11	30–60	150–900
	3–10, 3–10 NL	8–15	40–240
18 cm	4–7	30–60	150–900
	6–11, 6–9, narrow interval [†]	60–120	300–1 500
	3–10, 3–10 NL	15–30	75–450
24 cm	4–7, 3–7	45–90	200–1 300
	6–9, narrow interval [†]	80–170	400–2 000
	3–10, 3–10 NL	20–40	100–600

* When using cup loading an increased sample concentration will lead to an increased risk of protein precipitation in the sample cup. Maximum concentration of 100 μg protein / 100 μl sample solution (100 μl is the volume of the cup) is recommend. This is a general recommendation, which will function for most samples, but the maximum concentration that is possible to use varies greatly between sample types. For larger sample loads, rehydration loading is recommended.

[†] Immobiline DryStrip narrow intervals pH: 3.5–4.5, 4.0–5.0, 4.5–5.5, 5.0–6.0, and 5.5–6.7.



Table 12. Troubleshooting IPG strip rehydration in Reswelling Tray

Symptom	Possible cause	Remedy
Uneven or incomplete swelling of strips	Depending on the Immobiline DryStrip pH interval and the pH of the reswelling solution either the basic end or the acidic end will swell faster than the other. The strip may not necessarily be of an even thickness following rehydration.	
	The unopened IPG strips package was stored at or above room temperature for too long.	Store IPG strips sealed at temperatures below -20 °C.
	IPG strips were stored at or above room temperature for too long.	Do not allow dry IPG strips to sit at room temperature for longer than 10 min. Strips will pick up moisture from the air.
	Incorrect volume of rehydration solution used.	Make sure the correct amount of solution according to Table 10 is added to the slot in the Reswelling Tray.
	The rehydration time is too short.	Rehydrate the IPG strips for at least 10 h.

2.5.2 Preparing for IEF

The components of the 2-D Immobiline DryStrip Kit include a tray and electrode holder, anode and cathode electrodes, an Immobiline DryStrip aligner, a sample cup bar, and sample cups.



Procedures A and B below should be completed before the IPG strips are removed from the Reswelling Tray.

A. Prepare the Immobiline DryStrip Kit

1. Clean all components of the Immobiline DryStrip Kit

The Immobiline DryStrip tray, Immobiline DryStrip aligner, electrodes, sample cup bar, and sample cups must be clean and ready for use. Clean with detergent, rinse thoroughly with distilled water, and allow to dry.

2. Confirm electrical connections on Multiphor II

Check that the red bridging cable in the Multiphor II unit is connected.

3. Establish cooling

Set the temperature on MultiTemp III Thermostatic Circulator to 20 °C. Position the cooling plate on the Multiphor II unit and ensure that the surface is level.

6. Position the Immobiline DryStrip tray

Pipette approximately 3 to 4 ml of DryStrip Cover Fluid onto the cooling plate. Position the Immobiline DryStrip tray on the cooling plate so the red (anodic) electrode connection of the tray is positioned at the top of the plate near the cooling tubes. Remove any large bubbles between the tray and the cooling plate; small bubbles can be ignored. The DryStrip Cover Fluid at this point serves as an electrical insulating fluid to ensure good thermal contact between the cooling plate and the tray. Connect the red and black electrode leads on the tray to the Multiphor II unit.

7. Place the Immobiline DryStrip aligner

Pour about 10 ml of DryStrip Cover Fluid into the Immobiline DryStrip tray. Place the Immobiline DryStrip aligner, 12-groove-side-up, into the tray on top of the DryStrip Cover Fluid. The presence of air bubbles between the strip positions under the aligner will not affect the experiment. Avoid getting DryStrip Cover Fluid on top of the aligner at this point.

B. Prepare electrode strips

1. Cut electrode strips to size

Cut two IEF electrode strips to a length of 110 mm.

2. Soak electrode strips with distilled water

Place the electrode strips on a clean, flat surface such as a glass plate. Soak each electrode strip with 0.5 ml distilled water. Blot with tissue paper to remove excess water.



Important: Electrode strips must be damp, not wet. Excess water may cause streaking.



Note: Steps A and B above should be completed before proceeding.

C. IEF with rehydration loading

1. Remove the rehydrated IPG strip from the Immobiline DryStrip Reswelling Tray

To remove an IPG strip from the Reswelling Tray, slide the tip of a pair of forceps along the sloped end of the slot and into the slight depression under the IPG strip. Grab the end of the strip with the forceps and lift the strip out of the tray.

2. Position the IPG strip in the Immobiline DryStrip aligner (Fig 12)

Immediately transfer the rehydrated IPG strips to adjacent grooves of the aligner in the Immobiline DryStrip tray. Place the strips with the pointed (acidic) end at the top of the tray near the red electrode (anode). The blunt end should be at the bottom of the tray near the black electrode (cathode). Align the IPG strips so the anodic gel edges are lined up.

3. Attach the electrode strips

Place the moistened electrode strips across the cathodic and anodic ends of the aligned IPG strips. The electrode strips must at least partially contact the gel surface of each IPG strip.

4. Position the electrodes (Fig 13)

Each electrode has a side marked red (anode) or black (cathode). Align each electrode over an electrode strip, ensuring the marked side corresponds to the side of the tray giving electrical contact. When the electrodes are properly aligned, press them down to contact the electrode strips. Check that the IPG strips are still aligned in their grooves.



Fig 12. Positioning IPG strip gels in the Immobiline DryStrip aligner.



Fig 13. Alignment of electrodes over IPG strips.

2.5.3 Sample application by cup loading



If the sample was not applied by means of the rehydration solution, it can be applied using the sample cups, immediately prior to isoelectric focusing. When sample cups are used, the sample load limits are lower and more specific. Guidelines on suitable sample loads for different gradients and IPG strips are given in Table 11 on page 36.

These values should only be regarded as a rough guide. Suitable sample load will vary greatly between samples and with the sensitivity of the staining method used.

1. Prepare the sample

Prepare the sample in a solution similar in composition to the rehydration solution used.

2. Determine the point of sample application

The optimal application point depends on the characteristics of the sample. When the proteins of interest have acidic pIs or when SDS has been used in sample preparation, sample application near the cathode is recommended. Anodic sample application is necessary with pH 6–11 and 6–9 gradients and preferred when pH 3–10 gradients are used. The optimal application point can vary with the nature of the sample. Empirical determination of the optimal application point is best.

3. Position the sample cup bar (Fig 14)

Place sample cups on the sample cup bar, high enough on the bar to avoid touching the gel surface. Position the sample cup bar so the sample cups are a few millimeters away from the cathodic or anodic electrode, depending on your sample. The sample cups must face the electrode. The sample cup bar has a spacer on one side. Slide the sample cup bar towards the anode/cathode until the spacer just touches the anodic/cathodic electrode.

4. Press the sample cups against the IPG strips (Fig 14)

Move the sample cups into position, one sample cup above each IPG strip, and press the sample cups down to ensure good contact with each IPG strip. This is perhaps the most critical part of the setup. Check that strips are in their correct, straight position in the DryStrip aligner.

5. Apply DryStrip Cover Fluid

Once the sample cups are properly positioned, pour 70 to 80 ml DryStrip Cover Fluid into the tray to completely cover the IPG strips. If the DryStrip Cover Fluid leaks into the sample cups remove it with a pipette, correct the leakage and check for leakage again. Add approximately 150 ml of additional DryStrip Cover Fluid to completely cover the sample cups. The IPG strips are submerged under a layer of DryStrip Cover Fluid to prevent drying of the IPG strip, precipitation of the components of the rehydration solution and diffusion of gas into the IPG strip.

6. Apply the sample (Fig 15)

Apply sample (up to 100 μ l per IPG strip) into the sample cups by pipetting under the surface of the DryStrip Cover Fluid. The sample should sink to the bottom of the cup. Check for leakage.

7. Start IEF

Ensure the electrodes on the tray are connected and place the lid on the Multiphor II unit. Connect the leads on the lid to the power supply. Begin IEF.

Note: When sample is applied via sample cups, precipitates can form at the application point and the amount of protein that can be loaded is less than if the sample was included in the rehydration solution. Protein precipitation and aggregation at the application point can sometimes be avoided by observing the following:

- The sample should contain urea, non-ionic detergents, and IPG buffer or carrier ampholytes.
- Apply the sample in dilute solutions (60–100 μ g protein per 100 μ l).

For micropreparative applications, rehydration loading is recommended.

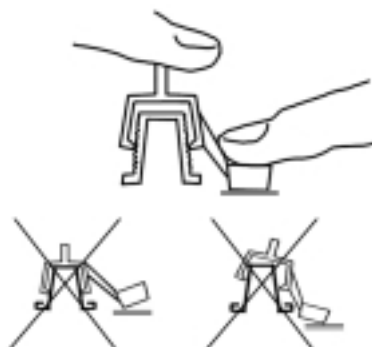

Fig 14. Attachment of sample cups to the cup bar and pressing of sample cups against IPG strips.

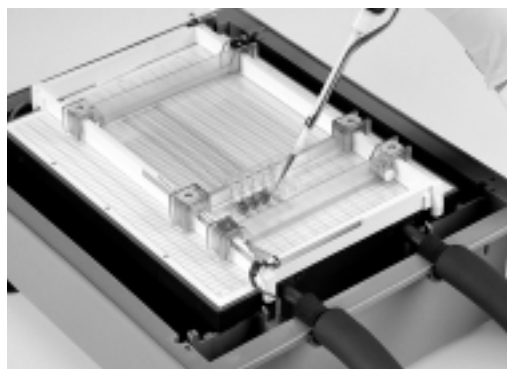

Fig 15. Applying sample into sample cups.

2.5.4 Paper-bridge loading (Fig 16)

Higher sample volumes and protein amounts can be applied with paper bridges, which are placed between the anodic or cathodic end of the IPG strip and the electrode strip. A large sample volume requires a large paper pad applied at the other side to absorb excess water. Paper bridges and electrode pads are cut from 1 mm-thick CleanGel™ electrode strips (see Ordering Information) to a size of 15 × 25 mm and with an arrowhead as shown in Figure 16. The rehydrated IPG strip is positioned directly on the glass bottom of the Immobiline DryStrip tray. The arrowheaded paper, to which 375 μ l sample solution has

been added, is then positioned at the anodic or the cathodic end of the IPG strip. To hold the paper bridge and IPG strip in place, press a sample cup positioned on the sample cup bar down on top of the arrowhead. Solution containing up to 10 mg protein (in 850 μ l sample solution applied to a 15 \times 50 paper bridge) can be loaded on a 18 cm long narrow pH range IPG DryStrip under favorable conditions (68). The application point (anodic or cathodic) is of primary importance for obtaining good results.

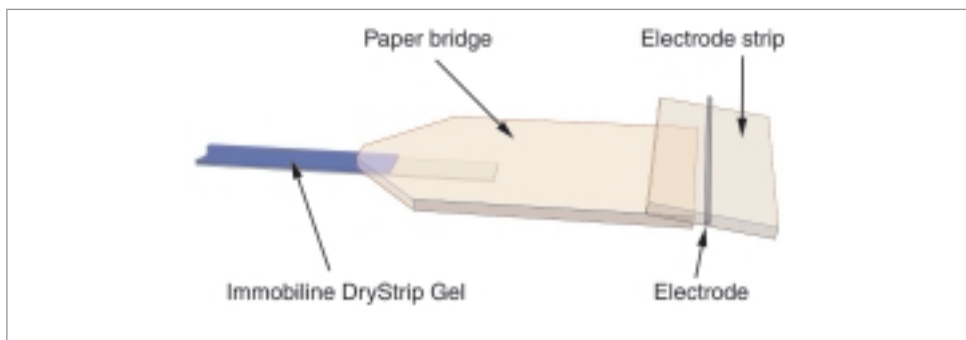



Fig 16. Setup for sample application via a paper bridge.

2.5.5 Isoelectric focusing guidelines

IEF in the Multiphor II system is conducted at very high voltages (up to 3 500 V) and very low currents (typically less than 1 mA) due to the low ionic strength within IPG strips. During IEF, the current decreases while the voltage increases as proteins and other charged components migrate to their equilibrium positions. In a typical IEF protocol, voltage is gradually increased to the final desired focusing voltage, which is held for up to several hours. With cup loading, a low initial voltage minimizes sample aggregation and a low initial voltage generally allows the parallel separation of samples with differing salt concentrations.

The *main factors* determining the required Voltage-hours (Vh) are the length of the IPG strips and the pH gradient used. Sample composition, rehydration solution composition, and sample application mode influence the required Voltage-hours. Table 13, (page 42) suggests Voltage-hours suitable for most samples with rehydration loading or anodic cup loading.

 *Cathodic* sample application on wide-range gradients pH 3–10 requires considerably longer focusing times than those stated in Table 13, especially if SDS-containing samples are used. As an example, a SDS solubilized serum protein sample applied at the cathodic end of a pH 3–10 NL gradient requires Vh in excess of 2–2.5 fold of that stated in Table 13 (69).

 Salt and buffer ions in the sample can require an increase of the time for phase 2 in comparison to the values given in Table 13, particularly when cup loading is used. High ion concentrations in the sample can also require an increase of the total Vh-requirement, as these ions have to be transported to the ends of the IPG strips. Larger quantities of protein require more time to focus.

 *Note:* Focusing for substantially longer than recommended will cause horizontal streaking and loss of proteins. This phenomenon is called "over-focusing". Therefore focusing time should be reduced to the minimum necessary (see section 5.0, page 77).

2.5.6 Protocol examples—Multiphor II

The protocols in Table 13 are suitable for first-dimension isoelectric focusing of protein samples in typical analytical quantities (see Tables 10 and 11, pages 35 and 36) with IPG Buffer concentrations of 0.5 to 2% in the rehydration solution. Optimal focusing time will vary with the nature of the sample, the amount of protein, and how the sample is applied.



For higher protein loads (up to 1 mg or more) the final focusing step of each protocol can be extended with an additional 20% of the total recommended V_h if necessary.



Note: Sample application onto pH 6–11 and 6–9 IPG strips by rehydration loading is less likely to result in high quality 2-D results and should be avoided. Samples should be applied using cup loading at the acidic end of the IPG strip.

2.5.7 Running a protocol

Ensure that the electrodes in the Immobiline Dry Strip tray are connected and place the lid on the Multiphor II unit. Connect the leads on the lid to the power supply. Ensure that the current check on the EPS 3501 XL power supply is switched off. Begin IEF.



As isoelectric focusing proceeds, the bromophenol blue tracking dye migrates toward the anode. Note that the dye front leaves the IPG strip well before focusing is complete, so clearing of the dye is no indication that the sample is focused. If the dye does not migrate, no current is flowing. If this occurs, check the contact between the electrodes and the electrode strips.

Table 13. Immobiline DryStrip IEF guidelines for Multiphor II

*Immobiline DryStrip		Cup loading or Rehydration loading †EPS 3501 XL power supply in gradient mode				*Immobiline DryStrip		Cup loading †EPS 3501 XL power supply in gradient mode			
Length	pH range(s)	Phase	Voltage (V)	Duration (h:min)	kVh	Length	pH range(s)	Phase	Voltage (V)	Duration (h:min)	kVh
7 cm	4–7	1	200	0:01	0.001	7 cm	6–11	1	200	0:01	0.01
		2	3 500‡	1:30	2.8			2	3 500‡	1:30	2.8
		3	3 500	0:55–1:30	3.2–5.2			3	3 500	0:40	2.3
		Total		2:25–3:00	6–8			Total		2:10	5
3–10, 3–10 NL	3–10 NL	1	200	0:01	0.001						
		2	3 500‡	1:30	2.8						
		3	3 500	0:35–1:05	2.2–3.7						
		Total		2:05–2:35	5–6.5						
11 cm	4–7	1	300	0:01	0.001	11 cm	6–11	1	300	0:01	0.01
		2	3 500‡	1:30	2.9			2	3 500‡	1:30	2.9
		3	3 500	2:20–3:30	8.1–12.1			3	3 500	2:05	7.1
		Total		3:50–5:00	11–15			Total		3:35	10
3–10	3–10	1	300	0:01	0.001						
		2	3 500‡	1:30	2.9						
		3	3 500	2:05–2:35	7.1–9.1						
		Total		3:35–4:05	10–12						
13 cm	4–7	1	300	0:01	0.001	13 cm	6–11	1	300	0:01	0.01
		2	3 500‡	1:30	2.9			2	3 500‡	1:30	2.9
		3	3 500	3:45–4:20	13.1–18.1			3	3 500	3:10	11.1
		Total		5:15–5:50	16–21			Total		4:40	14
3–10, 3–10 NL	3–10 NL	1	300	0:01	0.001						
		2	3 500‡	1:30	2.9						
		3	3 500	3:10–4:00	11.1–14.1						
		Total		4:40–5:30	14–17						
18 cm	4–7	1	500	0:01	0.001	18 cm	6–11	1	500	0:01	0.01
		2	3 500‡	1:30	3.0			2	3 500‡	1:30	3.0
		3	3 500	5:40–7:40	20–27			3	3 500	5:40	20.0
		Total		7:10–9:10	23–30			Total		7:10	23
3–10, 3–10 NL	3–10 NL	1	500	0:01	0.001	6–9	6–9	1	500	0:01	0.01
		2	3 500‡	1:30	3.0			2	3 500‡	1:30	3.0
		3	3 500	4:50–6:20	17–22			3	3 500	12:00	42
		Total		6:20–7:50	20–25			Total		13:30	45
Narrow intervals¶	Narrow intervals¶	1	500	0:01	0.001						
		2	3 500‡	1:30	3.0						
		3	3 500	13:20–16:20	47–57						
		Total		14:50–17:50	50–60						
24 cm	3–10	1	500	0:01	0.001	24 cm	6–9	1	500	0:01	0.01
		2	3 500‡	1:30	3.0			2	3 500‡	1:30	3.0
		3	3 500	7:40–10:40	27–37			3	3 500	16:20	57
		Total		9:10–12:10	30–40			Total		17:50	60
4–7, 3–7 NL, 3–10 NL	3–10 NL	1	500	0:01	0.001						
		2	3 500‡	1:30	3.0						
		3	3 500	12:00–16:20	42–47						
		Total		13:30–17:50	45–60						
Narrow Intervals¶	Narrow Intervals¶	1	500	0:01	0.001						
		2	3 500‡	1:30	3.0						
		3	3 500	22:00–27:40	77–97						
		Total		23:30–29:10	80–100						

* For all Immobiline DryStrip gels: Temperature: 20 °C, Current: 0.5 mA/strip, Power: 5 W total. Kilovolt-hour (kVh) values are recommended.

† Program EPS 3501 XL power supply with current check option turned off. IPG strip is rehydrated with a solution containing IPG Buffer of the corresponding pH gradient.

‡ During phase 2, the voltage will rise from the voltage set for phase 1 to 3 500 V. The voltage will remain at 3 500 V throughout phase 3.

¶ Immobiline DryStrip narrow intervals pH: 3.5–4.5, 4.0–5.0, 4.5–5.5, 5.0–6.0, and 5.5–6.7.

2.5.8 Preservation of focused IPG strips

After IEF proceed to the second-dimension separation immediately or store the IPG strips at -70 °C in screw-cap tubes. The 7 cm strips fit in disposable, 15 ml conical tubes; 11, 13, and 18 cm strips fit in 25 × 200 mm screw cap culture tubes; 18 and 24 cm strips fit into the Equilibration Tubes available from Amersham Biosciences.

2.5.9 Troubleshooting



Table 14 lists possible problems that could be encountered during IEF and how to solve them.

Table 14. Troubleshooting first-dimension IEF: Multiphor II and Immobiline DryStrip Kit

Symptom	Possible cause	Remedy
Sample cups leak	Incorrect handling and placement of sample cups.	Sample cups are fragile and should not be used too many times. Make sure the sample cups are aligned with the IPG strips. Make sure the bottom of the sample cups are flat against the gel surface of the IPG strips. <i>Note:</i> Leaks can often be detected prior to sample application: • Observe the IPG DryStrip Cover Fluid when it is poured into the Immobiline DryStrip Kit tray. If it leaks in through the bottom of the sample cups, reposition the cups, remove the cover fluid with a pipette, and check for leakage again. • An optional check for leakage is to add 0.01% bromophenol blue dye solution to the cups. If the dye leaks out of a cup, it must be corrected. (<i>Important:</i> the leaked detection dye must be removed from the sample cup before loading the sample).
Low current	This is normal for IPG gels. The gels have very low conductivity.	Usually an IPG run starts close to 1 mA and drops into the μ A range. This depends on the number of IPG strips in the instrument.
	Power supply cannot detect the low μ A range current and shuts off.	Because the EPS 3501 XL can operate under very low currents, it is recommended for use with Immobiline DryStrip Kit and Immobiline DryStrip gels. Make sure the low-current shut-off has been bypassed (see power supply instructions). IPG runs may start in a current range that is not detectable by the power supply.
	IPG Buffer omitted from rehydration solution.	Always include IPG buffer or Pharmalyte in the rehydration solution.
No current at start of run	No electrode contact or lack of electrical continuity.	Check to make sure all Multiphor II contacts are in place. Make sure the metal band within the electrode contacts the metal band along the side of the Immobiline DryStrip tray. Note that the metal band within the electrode is only on the end marked with the red or black circle. Ensure that the bridging cable under the cooling plate is properly installed.
	IPG strip is improperly rehydrated.	Ensure that the IPG strip is rehydrated along its entire length.
	The high voltage lead from the electrophoresis unit is not plugged into the power supply correctly.	Ensure that the plugs on the high-voltage leads fit securely into the output jacks on the power supply. Use the appropriate adapter if necessary.
Sample dye does not move out of the sample cup	It is normal for several hours to elapse before the sample dye leaves the sample cups.	
	The sample cups were pressed down so hard against the gel that they pushed through the gel to rest against the plastic backing. This blocks the current and physically prevents the protein from entering the IPG strip.	Replace IPG strip and re-apply sample cup.

continues on following page

Table 14. Troubleshooting first-dimension IEF: Multiphor II and Immobiline DryStrip Kit (continued)

Symptom	Possible cause	Remedy
Sample dye does not move out of the sample cup	The ionic strength of the sample is higher than the gel. As a result, the field strength in the sample zone is inadequate to move the protein out of the sample zone at an appreciable rate.	Dilute the sample as much as possible or, just prior to loading, dialyze the sample to remove salts.
Sparkling or burning of IPG strips	Conductivity of the sample/IPG strips is too high.	Ensure the sample is adequately desalted. Alternatively, before raising the voltage to maximum, include a prolonged low-voltage phase in the IEF protocol to allow the ions to move to the ends of the IPG strip.

2.6 Ettan IPGphor Isoelectric Focusing System

With the IPGphor Isoelectric Focusing system, both rehydration of the IPG strip and IEF occur in individual strip holders. Different strip holder lengths are available for different IPG strip lengths. The Ettan IPGphor Strip Holder is made of thermally conductive ceramics with built-in platinum electrodes and a transparent lid.

IPG strip holders have a special surface treatment to minimize protein adsorption. Because some cleaning agents can damage the surface, clean the strip holders only with the Ettan IPGphor Strip Holder Cleaning Solution as directed. The sample can be loaded by simply including it in the rehydration solution, or loaded separately just prior to IEF into small lateral sample wells or alternatively, into the loading cups of Cup Loading Strip Holder. Ettan IPGphor Cup Loading Strip Holder can accommodate Immobiline DryStrip gels up to 24 cm length and is equipped with movable platinum electrode contacts.

Once sample is applied to the IPG strip and a Strip Holder is in place on the Ettan IPGphor unit platform, the remaining steps are carried out automatically according to the chosen protocol. Up to 12 strip holders can be supported.

2.6.1 IPG strip rehydration—Ettan IPGphor Strip Holder

1. Prepare the strip holder(s)

Select the strip holder(s) corresponding to the IPG strip length chosen for the experiment.

Important: Handle the ceramic strip holders with care, as they are fragile.

Very Important: Wash each strip holder with detergent to remove residual protein. Use a neutral pH detergent, such as the Ettan IPGphor Strip Holder Cleaning Solution, to remove residual protein from these strip holders. Ettan IPGphor Strip Holder Cleaning Solution has been specifically formulated for removing protein deposits and will not damage the strip holder. Ettan IPGphor Strip Holder Cleaning Solution can be ordered in 950 ml bottles from Amersham Biosciences. See Ordering information.

Clean strip holders after each first-dimension IEF run. Do not let solutions dry in the strip holder. Cleaning may be more effective if the strip holders are first soaked a few hours overnight in a solution of 2–5% Ettan IPGphor Strip Holder Cleaning Solution in water.

1. First rinse off the strip holder. A mild liquid soap may be used to remove any residual DryStrip cover fluid.
2. Squeeze a few drops of Ettan IPGphor Strip Holder Cleaning Solution into the strip holder slot. Use a toothbrush and vigorous agitation to clean the strip holder.
3. Rinse well with distilled or deionized water. Thoroughly air dry the strip holders or dry well with a lint-free tissue prior to use.



Recalcitrant or dried-on protein deposits may be removed with hot (up to 95 °C) 1% (w/v) SDS. Add 1% (w/w) DTT for complete removal of sticky proteins. Rinse completely with distilled or deionized water after cleaning.

Handle clean strip holders with gloves to avoid contamination.

Important: Strip holders may be baked, boiled or, autoclaved. DO NOT EXPOSE THEM TO STRONG ACIDS OR BASES, INCLUDING ALKALINE DETERGENTS.

Note: The strip holder must be completely dry before use.

2. Apply the rehydration solution (Fig 17)

Pipette the appropriate volume of rehydration solution into each strip holder as indicated in Table 15. Deliver the solution slowly at a central point in the strip holder channel away from the sample application wells. Remove any larger bubbles.

Typical composition of rehydration solution: 8 M urea, 0.5% (w/v) CHAPS, 0.2% (w/v) DTT, 0.5% (v/v) IPG Buffer or Pharmalyte, 0.002% bromophenol blue.

Important: To ensure complete sample uptake, do not exceed the recommended volume of rehydration solution, see Table 15.

3. Position the IPG strip (Fig 18)

Remove the protective cover foil from the IPG strip starting at the acidic (pointed) end. Removal from the acidic (pointed) end prevents damage to the basic (square) end of the IPG strip, which is generally softer. Position the IPG strip with the gel side down and the pointed (anodic) end of the strip directed toward the pointed end of the strip holder. Pointed end first, lower the IPG strip onto the solution. To help coat the entire strip, gently lift and lower the strip and slide it back and forth along the surface of the solution, tilting the strip holder slightly as needed to assure complete and even wetting.

Finally, lower the cathodic (square) end of the IPG strip into the channel, making sure that the gel contacts the strip holder electrodes at each end. (The gel can be visually identified once the rehydration solution begins to dye the gel). Be careful not to trap air bubbles under the IPG strip.

4. Apply DryStrip Cover Fluid

Apply IPG Cover Fluid to minimize evaporation and urea crystallization. Pipette the fluid dropwise into one end of the strip holder until one half of the IPG strip is covered. Then pipette the fluid dropwise into the other end of the strip holder, adding fluid until the entire IPG strip is covered.

5. Place the cover on the strip holder

Pressure blocks on the underside of the cover assure that the IPG strip maintains good contact with the electrodes as the gel swells.

6. Allow the IPG strip to rehydrate

Rehydration can proceed on the bench top or on the Ettan IPGphor unit platform. Ensure that the strip holder is on a level surface. A minimum of 10 h is required for rehydration; overnight is recommended. The rehydration period can be programmed as the first step of an Ettan IPGphor protocol. This is especially convenient if temperature control during rehydration is a concern.



Fig 17. Applying rehydration solution into the strip holder.

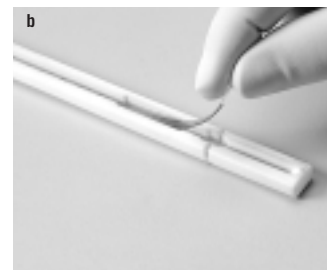
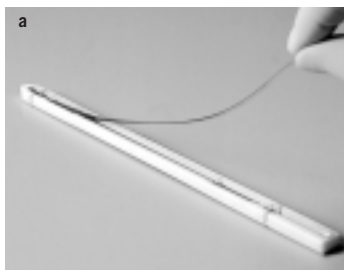

Fig 18a, b. Positioning the IPG strip.

A. Rehydration loading

There are two possible rehydration conditions:

1. Passive rehydration

No electric field is applied during rehydration.

2. Rehydration under voltage

In some cases, rehydration under a low voltage (30–120 V) facilitates the entry of high-molecular weight proteins (70).

B. Optional: Apply electrode pads

During isoelectric focusing the transport of ions, proteins, and IPG buffer to the electrodes is accompanied by transport of water.

For large sample loads and narrow Immobiline DryStrip gels, better results are obtained by applying damp paper pads between the IPG strip and each strip holder electrode just before IEF to adsorb excess water.

1. Prepare electrode pads

To apply, cut two 3 mm-wide electrode pads from a paper IEF electrode strip. Place on a clean, flat surface such as a glass plate and soak with deionized water. Remove excess water by blotting with tissue paper.

Important: Electrode pads must be damp, not wet.

2. Position electrode pads

Using forceps or tweezers, lift one end of the rehydrated IPG strip. Position an electrode pad over the electrode, then lower the IPG strip back into place. Repeat at the other end.



C. Apply sample after gel rehydration

If the sample was not applied as a part of the rehydration solution, it can be applied immediately prior to IEF.

1. Prepare sample

Prepare the sample in a solution similar in composition to the rehydration solution used.

2. Apply sample (Fig 19)

Pipette the sample into either or both of the lateral wells at either end of the strip holder. Introduce the sample below the DryStrip Cover Fluid.

Up to 7.5 μl of sample solution can be added to each side (i.e. 15 μl per well or 30 μl total if both sides of both wells are used).

Note: The IPG strip backing is impermeable; do not apply the sample to the back of the strip.

Replace cover on strip holder.

Table 15. Rehydration solution volume per Immobiline DryStrip

IPG strip length (cm)	Total volume per strip* (μl)
7 cm	125 μl
11 cm	200 μl
13 cm	250 μl
18 cm	340 μl
24 cm	450 μl

*Including sample, if applied.



Fig 19. Applying sample after gel rehydration.

2.6.2 IPG strip rehydration—Ettan IPGphor Cup Loading Strip Holder

Several sample application methods are available when using Ettan IPGphor Cup Loading Strip Holder:

- Cup loading is recommended for sample volumes up to 100 μl , and a maximum protein concentration of 100 μg protein/100 μl sample solution (100 μl is the volume of the cup). Larger sample loads can lead to increased protein precipitation in the sample cup.
- Rehydration loading is preferred for large sample volumes (greater than 100 μl) and sample amounts.
- Paper-bridge loading is selected for very large sample volumes and preparative electrophoresis and is particularly applicable when using basic pH intervals (pH 6–9 and pH 6–11).

Details of appropriate sample loads for silver and Coomassie staining using rehydration loading and cup loading using Ettan IPGphor Cup Loading Strip Holder are given in Table 16.



As mentioned earlier, cup loading has been found to improve protein 2-D patterns, particularly with basic IPG strips (pH 6–9 and pH 6–11). Under conditions where substantial water transport (electroendosmosis) accompanies focusing, such as with protein loads in excess of 1 mg, the face-up mode frequently yields better resolution.

Table 16. Suitable sample loads for silver and Coomassie staining using rehydration loading and cup loading

Immobiline DryStrip (pH)	Suitable sample load (μg of protein)		
	Silver stain	Coomassie stain	
7 cm	4–7	4–8	20–120
	6–11	8–16	40–240
	3–10, 3–10 NL	2–4	10–60
11 cm	4–7	10–20	50–300
	6–11	20–40	100–600
	3–10 L	4–8	20–120
13 cm	4–7	15–30	75–450
	6–11	30–60	150–900
	3–10, 3–10 NL	8–15	40–240
18 cm	4–7	30–60	150–900
	6–11, 6–9, narrow interval*	60–120	300–1 500
	3–10, 3–10 NL	15–30	75–450
24 cm	4–7, 3–7	45–90	200–1 300
	6–9, narrow interval*	80–170	400–2 000
	3–10, 3–10 NL	20–40	100–600

* Immobiline DryStrip narrow intervals pH: 3.5–4.5, 4.0–5.0, 4.5–5.5, 5.0–6.0, and 5.5–6.7.

When using cup loading, an increased sample concentration will lead to an increased risk of protein precipitation in the sample cup. Maximum concentration of 100 μg protein / 100 μl sample solution (100 μl is the volume of the cup) is recommended. This is a general recommendation, which will function for most samples, but the maximum concentration possible to use varies greatly between sample types. For larger sample loads, rehydration loading is recommended.

Strip holder

Ettan IPGphor Cup Loading Strip Holder is made of aluminum oxide ceramic for efficient heat transfer and temperature control during IEF. Two areas of metal plating on the bottom extend up the sides of the strip holder. These plated areas make contact with the power supply contact pads when placed on the Ettan IPGphor separation platform. Ettan IPGphor can accommodate a maximum of 9 Cup Loading Strip Holders.

Protrusions along the channel inside the strip holder align the rehydrated IPG strip, keeping it straight and centered when placed inside the strip holder. The anodic end of the strip holder is somewhat pointed to indicate the direction of placement of the pointed IPG strip.



The strip holders have a special surface treatment to minimize protein adsorption. Because some cleaning agents can damage the surface, clean the strip holders only with the Ettan IPG Strip Holder Cleaning Solution as directed. The strip holders are very fragile and should be handled with care.

Electrodes

The moveable electrode clips can be placed anywhere along the chamber where the electrode bosses make electrical contact with the conducting rails on the sides of the strip holder. Strips from 7 cm to 24 cm long can be used.

Sample cups

Sample cups can be placed almost anywhere along the length of the Ettan IPGphor Cup Loading Strip Holder that is not blocked by a protrusion. For proper sealing of the cup to the gel, the feet of the sample cup must all rest on the bottom of the channel.

Cover



The cover is used to ensure that the electrodes stay in place and that they are in good contact with the IPG strip. The cover also applies gentle pressure to assure that the strip holder makes good contact with the IPGphor separation platform and power supply contact pads.

Immobiline DryStrip Cover Fluid



The Immobiline DryStrip Cover Fluid is required to ensure that the rehydrated Immobiline DryStrip gels do not dry out during electrophoresis. Without cover fluid, the strips will dry out, urea crystallize, and the sample will not focus properly.

Electrode pads



Although electrode pads are not required to make electrical contact between the IPG strip and the electrode, they can improve the quality of results, particularly on narrow-range Immobiline DryStrip gels. The pads absorb excess water, as well as proteins with pIs that are outside the pH range of the IPG strip.

A. Immobiline DryStrip Reswelling Tray

IPG strips must be rehydrated prior to IEF. The IPG strips are rehydrated in the Immobiline DryStrip Reswelling Tray if Ettan IPGphor Cup Loading Strip Holders are used for IEF.

Immobiline DryStrip Reswelling Tray has 12 independent reservoir slots that can each hold a single IPG strip up to 24 cm long. Separate slots allow the rehydration of individual IPG strips in a minimal volume of solution.

1. Prepare the Reswelling Tray (Fig 10, page 35)

Slide the protective lid completely off the tray and level the tray by turning the leveling feet until the bubble in the spirit level is centered. Ensure the tray is clean and dry.

2. Apply the rehydration solution

Pipette the appropriate volume into each slot as indicated in Table 15, page 46.

Typical composition of rehydration solution:

8 M urea, 0.5% (w/v) CHAPS, 0.2% (w/v) DTT, 0.5% (v/v) IPG Buffer or Pharmalytes, 0.002% bromophenol blue.

The solution is either mixed with the sample solution for rehydration loading, or is applied as such for later cup loading or paper-bridge loading. Deliver the solution slowly at a central point in the slot. Remove any larger bubbles.

Important: To ensure complete fluid (and sample) uptake, do not apply excess rehydration solution.

3. Position the IPG strip (Fig 11, page 35)

Remove the protective cover from the IPG strip starting at the acidic (pointed) end, because of its superior mechanical stability. Position the IPG strip as shown in Figure 11, with the gel side down and the pointed end of the strip against the sloped end of the slot. Lower the IPG strip onto the solution. To help coat the entire IPG strip, gently lift and lower the strip and slide it back and forth along the surface of the solution. Be careful not to trap bubbles under the IPG strip.

4. Overlay the IPG strip with DryStrip Cover Fluid

Overlay each IPG strip with 3 ml of DryStrip Cover Fluid to minimize evaporation and prevent urea crystallization.

5. Allow the IPG strip to rehydrate

Slide the lid onto the Reswelling Tray and allow the IPG strips to rehydrate at room temperature. A minimum of 10 h is required for rehydration; overnight is recommended. If the IPG strips swell unevenly, refer to Table 12 on page 36.

Note: Rehydrate the IPG strips using the Immobiline DryStrip Reswelling Tray. If the Immobiline DryStrip Reswelling Tray is not available, strips can be rehydrated in the Ettan IPGphor Strip Holder.

Note: Rehydration in the Ettan IPGphor Cup Loading Strip Holder is **not** recommended: the channel is too wide for the rehydration volume.

For rehydration in Ettan IPGphor Strip Holder see page 44.

B. Prepare the Ettan IPGphor Cup Loading Strip Holder

1. Position the strip holder on the Ettan IPGphor platform

Due to the high voltage applied to the Ettan IPGphor Cup Loading Strip Holder it is important that it be clean and dry. The pointed end of the strip holder should contact the anodic electrode area (+) and the blunt end should contact the cathodic electrode area (-) of the Ettan IPGphor separation platform.

2. Transfer the strips to the Ettan IPGphor Cup Loading Strip Holder

The strips should be placed face up in the tray with the anodic (+, pointed) end of the IPG strip toward the pointed end of the strip holder. The strip must be positioned so that the gel overlaps the ends of both plated regions of the strip holder. The cathodic end of the IPG strip must be approximately 1.5 cm from the end of the channel and in electrical contact with the cathodic rails via the electrode clips (Fig 20). Center the strip down the length of the strip holder channel. Protrusions along the sides guide the strip approximately straight although some manual adjustment of the strip may be necessary.

3. Overlay Immobiline DryStrip Cover fluid across the surface of the IPG strip

It is important to distribute the oil evenly across the IPG strip and down the entire length of the Ettan IPGphor Cup Loading Strip Holder. Use only enough oil to cover the strip without overfilling (3–5 ml).



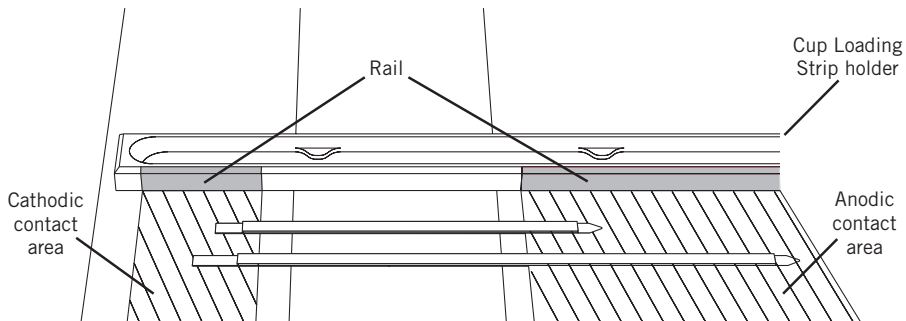

Fig 20. Positioning the IPG strips so that the gels are in electrical contact with the rails via the electrode clips.

4. Optional:

Cut electrode pads from IEF electrode strips about 5 mm long. Two pads per strip holder are required. Wet the pads with deionized water and blot them almost completely dry. Longer pads can be used if desired. If using longer pads, one end of the pad should overlap the end of the gel on the IPG strip. The electrode must contact the other end of the pad.

Place pads on both ends of the IPG strip (Fig 21). Slide an electrode down on top of each pad. Depending on the thickness of the IEF pad, the electrode may not feel solid on top of the filter paper. However, pressure applied by the cover will ensure complete contact when the lid of the Ettan IPGphor unit is closed.

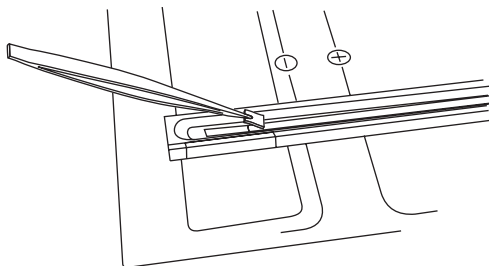

Fig 21. Placing a filter paper pad at the end of the gel strip.

C. Rehydration loading

Mix the sample with rehydration solution (see page 48, A. Immobiline DryStrip Reswelling Tray). When the IPG strips are rehydrated with the sample proteins, continue directly with isoelectric focusing.

D. Cup loading

1. Place the sample cup over the IPG strip

Do not place the cup with the feet over an alignment protrusion; the cup will not seat squarely and seal against the IPG strip. However, the sample cup can straddle these protrusions. Press the cup down until fully seated against the bottom of the strip holder. The feet on the sample cup stop the cup at a height above the floor of the strip holder sufficient to seal against the strip without cutting into it. Make sure the cup and electrodes are positioned properly prior to loading the sample. For basic IPG strips, superior focusing patterns are generally obtained when the sample cup is placed as close to the anodic (+) electrode as possible.

2. Optional:

To confirm the sample cup has sealed, pipette 100 μ l of Immobiline DryStrip Cover Fluid into the cup. Check the seal. Remove the fluid prior to loading the sample.

3. Three common causes of leakage include:

- A foot of the cup is resting on top of one of the protrusions. Reposition the cup and recheck for leakage.
- The gel strip is not centered in the channel. Remove the cup and the electrodes, center the strip, reposition the cup, and check again.
- The strip may not have rehydrated properly. Examine the strip closely for a thin region in which the cup may not be able to seal properly. Be sure to use the proper volume of rehydration solution for a sufficient time to allow complete rehydration.

4. Pipette up to 100 μ l of sample into the sample cup

5. Place the cover over the strip holder

E. Paper-bridge loading

Very large sample volumes and protein amounts can be applied with paper bridges, which are placed between the anodic or cathodic end of the IPG strip and the electrode pad. Paper bridges or electrode pads are cut from a 1 mm-thick CleanGel™ electrode strip, see Ordering information. Solution containing up to 5 mg protein can be loaded on an 18 cm-long narrow pH range Immobiline DryStrip gel (68).

A large sample volume requires that a large paper pad or arrowhead paper bridges be applied at the other end of the IPG strip to absorb excess water. Figure 22 below shows the arrangement used when sample is applied to a paper bridge positioned between the anode and an 18 cm long-IPG strip. Paper bridges are cut from the 1 mm-thick CleanGel electrode strips to a size of 8 × 45 mm and 8 × 35 mm to fit at the anodic and cathodic end of the Cup Loading Strip Holder. The paper bridge is soaked with distilled water and blotted with a tissue paper to become damp, not wet. Sample solution is applied to the paper bridge (450 μ l for anodic sample application and 350 μ l for cathodic sample application). The rehydrated IPG strip is first positioned in the bottom of the strip holder. Then the paper bridge positioned as indicated in Figure 22. With anodic application the anode is positioned as far out as possible in the electrode holder, while the cathode is positioned close to the end of the IPG strip to ensure good contact between electrode pad and IPG strip. A 6 mm soft plastic tubing is positioned as indicated in Figure 22. When the cover is placed over the strip holder it will press down the tubing and ensure good contact between the paper bridge and IPG strip. Solutions containing up to 5 mg protein can be loaded on an 18 cm long narrow pH range IPG strip.

Note: The application point (anodic or cathodic) is an important factor for obtaining good results.

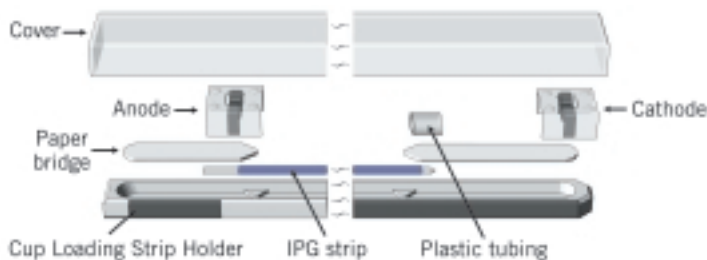

Fig 22. Equipment used for paper-bridge loading of large sample volumes.

2.6.3 Isoelectric focusing guidelines

IEF in the Ettan IPGphor system is conducted at very high voltages (up to 8 000 V) and very low currents (typically less than 50 μ A per IPG strip) due to the low ionic strength within IPG strips. During IEF, the current decreases while the voltage increases as proteins and other charged components migrate to their equilibrium positions. A typical IEF protocol generally proceeds through a series of voltage steps that begins at a relatively low value. Voltage is gradually increased to the final desired focusing voltage, which is held for several hours. A low initial voltage minimizes sample aggregation and allows the parallel separation

of samples with differing salt concentrations. A gradual increase in voltage is particularly advised for higher protein loads (100 µg or more per IPG strip).

Many factors affect the amount of time required for complete focusing, and each specific set of conditions (e.g. sample and rehydration solution composition, IPG strip length, and pH gradient) requires an empirical determination for optimal results. An approximate time for complete focusing is given in the example protocols provided in Table 17. Factors that increase the required focusing time include residual ions, which must move to the ends of the IPG strips before protein focusing can occur and the presence of IPG Buffers or Pharmalyte, which contributes to the ionic strength of the electrophoresis medium. A higher IPG Buffer concentration increases the conductivity of the IPG strip, resulting in a lower final voltage when the system is limited by the maximum current setting.



Longer focusing times may therefore be required at IPG Buffer/Pharmalyte concentrations higher than 0.5%.



For higher protein loads (up to 1 mg or more) the final focusing step of each protocol can be extended with an additional 20% of the total recommended V_h if necessary.



Note: Exceeding the current limit of 50 µA/IPG strip is not recommended, as this may result in excessive heat generation and may damage the IPG strip and/or strip holder. Under extreme circumstances, the IPG strip may burn.



Note: Over-focusing can sometimes occur on longer runs and may contribute to horizontal streaking, visible in the 2-D result. (See also section 5.0, page 77).

2.6.4 Protocol examples—Ettan IPGphor

These protocols are suitable for first-dimension isoelectric focusing of protein samples suspended in rehydration solution in typical analytical quantities (1 to 100 µg).

The protocols are optimized for a rehydration solution containing 0.5% IPG buffer or Pharmalyte. The recommended current limit is 50 µA/IPG strip. Recommended focusing times are given, but the optimal length of time will depend on the nature of the sample, the amount of protein, and the method of sample application. Please refer to the Ettan IPGphor user manual for instructions on how to program a protocol.

2.6.5 Running a protocol

Ensure that the strip holders are properly positioned on the Ettan IPGphor platform. (Use the guidemarks along the sides of the platform to position each strip holder and check that the pointed end of the strip holder is over the anode (pointing to the back of the unit) and the blunt end is over the cathode. Please refer to the Ettan IPGphor User Manual for complete details). Check that both external electrode contacts on the underside of each strip holder make metal-to-metal contact with the platform.

Close the safety lid. At least two of the three pressure pads under the safety lid must press gently against the cover of each strip holder to ensure contact between the electrodes and the electrode areas. Begin IEF.



As isoelectric focusing proceeds, the bromophenol blue tracking dye migrates toward the anode. Note that the dye front leaves the IPG strip well before focusing is complete, so clearing of the dye is no indication that the sample is focused. If the dye does not migrate, no current is flowing. If this occurs, check the contact between the external face of the strip holder electrodes and the electrode areas on the instrument and between the rehydrated gel and the internal face of the electrodes.



Note: it is possible that the programmed maximum voltage will not be reached with the shorter IPG strips or with samples with high conductivity.

Table 17. Guidelines for Ettan IPGphor with rehydration loading/IEF for Immobiline Dry Strip, pH 4–7, 3–10, 3–10 NL, and narrow pH intervals. Voltage step and hold mode, 50 μ A/IPG strip, 0.5% IPG buffer, 20 °C for both rehydration and IEF. Rehydration time 12 h. (The total rehydration time can be adjusted somewhat for convenience, but must be greater than 10 h)

Immobiline DryStrip		Rehydration loading				
Length	pH range(s)	Step and voltage mode	Voltage (V)	Step duration [†] (h:min)	Volt-hours (kVh)	
7 cm	3–10	1 Step and Hold	500	0:30	0.25	
	3–10 NL	2 Step and Hold	1 000	0:30	0.5	
	4–7	3 Step and Hold	5 000*	1:40	7.5	
		Total		2:40	8.0	
11 cm	3–10	1 Step and Hold	500	1:00	0.5	
	4–7	2 Step and Hold	1 000	1:00	1.0	
		3 Step and Hold	8 000*	1:50	12.5	
		Total		3:50	14.0	
13 cm	3–10	1 Step and Hold	500	1:00	0.5	
	3–10 NL	2 Step and Hold	1 000	1:00	1.0	
	4–7	3 Step and Hold	8 000*	2:00	14.5	
		Total		4:00	16.0	
18 cm	3–10	1 Step and Hold	500	1:00	0.5	
	3–10 NL	2 Step and Hold	1 000	1:00	1.0	
	4–7	3 Step and Hold	8 000*	4:00	30.5	
		Total		6:00	32.0	
		Narrow intervals [‡]	1 Step and Hold	500	1:00	0.5
			2 Step and Hold	1 000	1:00	1.0
24 cm	3–10	1 Step and Hold	500	1:00	0.5	
	3–10 NL	2 Step and Hold	1 000	1:00	1.0	
	4–7	3 Step and Hold	8 000*	8:20	62.5	
	3–7	Total		10:20	64.0	
		Narrow intervals [‡]	1 Step and Hold	500	1:00	0.5
			2 Step and Hold	1 000	1:00	1.0
		3 Step and Hold	8 000*	10:30	94.5	
		Total		12:30	96.0	

* This voltage may not be reached within the suggested step duration.

[†] The sample entry phase step 1 and 2 should be extended for high protein loads, or for convenience, if the strips are to be run overnight.

[‡] Narrow intervals, 3.5–4.5, 4.0–5.0, 4.5–5.5, 5.0–6.0, and 5.5–6.7.

After IEF, proceed to the second-dimension separation immediately or store the IPG strips at -70 °C in screw-cap tubes. The 7 cm strips fit in disposable, 15 ml conical tubes; 11, 13, and 18 cm strips fit in 25 × 200 mm screw cap culture tubes; 18 and 24 cm strips in the Equilibration Tubes available from Amersham Biosciences.

Table 18. Guidelines for Ettan IPGphor with Cup Loading Strip Holder for broad, medium, and narrow pH range Immobiline DryStrip gels. Voltage gradient and step and hold mode, 50 μ A/IPG strip, 0.5%* IPG buffer, 20 °C for IEF

Immobiline DryStrip		Running conditions for cup-loading application method				Running conditions for paper-bridge application method	
Length	pH range(s)	Step and voltage mode	Voltage (V)	Duration (h:min)	Volt-hours (kVh)	Duration (h:min)	Volt-hours (kVh)
7 cm	3–10	1 Gradient	500	0:01	0.01	0:01	0.01
	3–10 NL	2 Gradient	4 000 [†]	1:30	3.4	2:30	5.6
	4–7	3 Step and Hold	5 000 [†]	0:45	3.7	0:30	2.5
	6–11	Total		2:15	7.1	3:00	8.0
11 cm	3–10	1 Gradient	500	0:01	0.01	0:01	0.01
	4–7	2 Gradient	4 000 [†]	1:30	3.4	2:30	5.6
		3 Step and Hold	8 000 [†]	1:30	10.6	1:40	12.0
		Total		3:00	14.0	4:10	17.6
6–11	1 Gradient	500	0:01	0.01	0.01	0:01	0.01
	2 Gradient	4 000 [†]	1:30	3.4	2:30	5.6	
	3 Step and Hold	8 000 [†]	1:15	8.5	1:30	10.0	
	Total		2:45	12	4:00	15.6	
13 cm	3–10	1 Gradient	500	0:01	0.01	0:01	0.01
	3–10 NL	2 Gradient	4 000 [†]	1:30	3.4	2:30	5.6
	4–7	3 Step and Hold	8 000 [†]	1:50	13.5	2:10	15.2
	Total			3:50	17	4:40	20.8
6–11	1 Gradient	500	0:01	0.01	0.01	0:01	0.01
	2 Gradient	4 000 [†]	1:30	3.4	2:30	5.6	
	3 Step and Hold	8 000 [†]	1:40	11.6	1:50	13.4	
	Total		3:10	15	4:20	19.0	
18 cm	3–10	1 Gradient	500	0:01	0.01	0:01	0.01
	3–10 NL	2 Gradient	4 000 [†]	1:30	3.4	2:30	5.6
	4–7	3 Step and Hold	8 000 [†]	3:10	24.6	3:30	27.3
	Total		4:40	28	6:00	33	
6–9	1 Gradient	500	0:01	0.01	0.01	0:01	0.01
	2 Gradient	4 000 [†]	1:30	3.4	2:30	5.6	
	3 Step and Hold	8 000 [†]	5:20	41.6	5:40	44.3	
	Total		6:50	45	8:10	50	
Narrow intervals [‡]	1 Gradient	500	0:01	0.01	0.01	0:01	0.01
	2 Gradient	4 000 [†]	1:30	3.4	2:30	5.6	
	3 Step and Hold	8 000 [†]	7:10	56.6	7:40	60.3	
	Total		8:40	60	10:10	66	
6–11	1 Gradient	500	0:01	0.01	0.01	0:01	0.01
	2 Gradient	4 000 [†]	1:30	3.4	2:30	5.6	
	3 Step and Hold	8 000 [†]	2:40	20.6	2:50	22.3	
	Total		4:10	24	5:20	28	
24 cm	3–10	1 Gradient	500	0:01	0.01	0:01	0.01
	3–10 NL	2 Gradient	4 000 [†]	1:30	3.4	2:30	5.6
	4–7	3 Step and Hold	8 000 [†]	6:30	51.6	7:40	60.0
	3–7	Total		8:00	55	10:10	65
6–9	1 Gradient	500	0:01	0.01	0.01	0:01	0.01
	2 Gradient	4 000 [†]	1:30	3.4	2:30	5.6	
	3 Step and Hold	8 000 [†]	7:10	56.6	11:00	88.0	
	Total		8:40	60	15:30	106	
Narrow intervals [‡]	1 Gradient	500	0:01	0.01	0.01	0:01	0.01
	2 Gradient	4 000 [†]	1:30	3.4	2:30	5.6	
	3 Step and Hold	8 000 [†]	12:00	95.6	14:20	114.4	
	Total		13:30	99	16:50	120	

* If 1 or 2% IPGbuffer is used, decrease the maximum voltage to 3 500 V for 7 cm strips, 5 500V for 11 cm strips, and 6 500V for 13 cm strips.

[†] This voltage may not be reached within the suggested step duration.

[‡] Narrow intervals, 3.5–4.5, 4.0–5.0, 4.5–5.5, 5.0–6.0, and 5.5–6.7.



2.6.6 Troubleshooting

Table 19 lists possible problems that could be encountered during IEF and how to solve them.

Table 19. Troubleshooting first-dimension IEF: Ettan IPGphor

Symptom	Possible cause	Remedy
Current is too low or zero	Electrical continuity is impeded.	Check the external electrode contacts: The electrodes at the bottom of the strip holder (one at each end) must make metal-to-metal contact with the appropriate electrode contact area. Check the internal electrode contacts: The gel (which becomes visible because of the dye in the rehydration solution) must contact both electrodes in the strip holder. Check that the IPG strip is fully rehydrated along its entire length. Electrical contact at the electrodes is reduced by incomplete rehydration.
Voltage too low or does not reach the maximum set value	The Ettan IPGphor protocol settings are incorrect for the experiment	Check that the current limit is properly set. Check that the actual number of strips on the Ettan IPGphor platform equals the number of strips entered in the protocol.
	Conductivity/ionic strength is too high.	Prepare the sample to yield a salt concentration less than 10 mM. The recommended IPG Buffer concentration is 0.5%. A maximum of 2% is advisable only if sample solubility is a problem.
Sparking or burning in the strips	Current limit setting is too high.	Do not exceed the maximum recommended setting of 50 μ A per IPG strip.
	The IPG strip is not fully rehydrated.	Ensure the IPG strips are rehydrated with a sufficient volume of rehydration solution. Remove any large bubbles trapped under the IPG strip after placing on rehydration solution. Check that the entire IPG strip surface is wetted.
	The IPG strip dried during IEF.	Always apply DryStrip Cover Fluid to prevent dehydration of a rehydrated IPG strip.

Chapter 3

Second-dimension SDS-PAGE

3.0 Second-dimension SDS-PAGE—overview

After IEF, the second-dimension separation can be performed on various flatbed or vertical systems, depending on factors such as those discussed in “Equipment Choices” on page 12. SDS-PAGE consists of four steps: (1) Preparing the second-dimension gel, (2) equilibrating the IPG strip(s) in SDS buffer, (3) placing the equilibrated IPG strip on the SDS gel, and (4) electrophoresis.

In this guide, the equilibration step is described first because it is a protocol common to both vertical and flatbed systems. Gel preparation, IPG strip placement, and electrophoresis protocols, on the other hand, are specific to the orientation of the gel. Sections 3.3 and 3.4 describe these protocols as they apply to vertical systems and Multiphor II flatbed systems, respectively. Note however, that the second-dimension gel must be prepared before the equilibration step is started.

3.1 Background to SDS-PAGE

SDS-PAGE (SDS-polyacrylamide gel electrophoresis) is an electrophoretic method for separating polypeptides according to their molecular weights (M_r). The technique is performed in polyacrylamide gels containing sodium dodecyl sulfate (SDS). The intrinsic electrical charge of the sample proteins is not a factor in the separation due to the presence of SDS in the sample and the gel. SDS is an anionic detergent, that, when in solution in water, forms globular micelles composed of 70–80 molecules with the dodecyl hydrocarbon moiety in the core and the sulfate head groups in the hydrophilic shell. SDS and proteins form complexes with a necklace-like structure composed of protein-decorated micelles connected by short flexible polypeptide segments (71). The result of the necklace structure is that large amounts of SDS are incorporated in the SDS-protein complex in a ratio of approximately 1.4 g SDS/g protein. SDS masks the charge of the proteins themselves and the formed anionic complexes have a roughly constant net negative charge per unit mass. Besides SDS a reducing agent such as dithiothreitol (DTT) is also added to break any -S-S-linkages present in the proteins. When proteins are treated with both SDS and a reducing agent, the degree of electrophoretic separation within a polyacrylamide gel depends largely on the molecular weight of the protein. In fact, there is an approximately linear relationship between the logarithm of the molecular weight and the relative distance of migration of the SDS-polypeptide complex. (*Note:* This linear relationship is only valid for a certain molecular weight range, which is determined by the polyacrylamide percentage).

The most commonly used buffer system for second-dimension SDS-PAGE is the tris-glycine system described by Laemmli (72). This buffer system separates proteins at high pH, which confers the advantage of minimal protein aggregation and clean separation even at relatively heavy protein loads. The Laemmli buffer system has the disadvantage of a limited gel shelflife.

Ettan DALT precast gels utilize a new buffer system based on piperidinopropionamide (PPA), which combines long shelflife with the high separation pH of the Laemmli system.

Other buffer systems can also be used, particularly the Tris-tricine system of Schägger and von Jagow (73) for resolution of polypeptides in the M_r below 10 000. ExcelGel precast gels for second-dimension SDS-PAGE on the Multiphor II flatbed system utilize a different Tris-tricine buffer system.

3.2 IPG strip equilibration

The equilibration step saturates the IPG strip with the SDS buffer system required for the second-dimension separation. The equilibration solution contains buffer, urea, glycerol, reductant, SDS, and dye. An additional equilibration step replaces the reductant with iodoacetamide.



Note: Equilibration is always performed immediately prior to the second-dimension run, never prior to storage of the IPG strips at $-40\text{ }^{\circ}\text{C}$ or lower.

3.2.1 Equilibration solution components

Equilibration introduces reagents essential for the second-dimension separation.



Equilibration buffer (50 mM Tris-HCl, pH 8.8) maintains IPG strip pH in a range appropriate for electrophoresis.



Urea (6 M) together with glycerol reduces the effects of electroendosmosis by increasing the viscosity of the buffer (4). Electroendosmosis is due to the presence of fixed charges on the IPG strip in the electric field and can interfere with protein transfer from the IPG strip to the second-dimension gel.



Glycerol (30%) together with urea reduces electroendosmosis and improves transfer of protein from the first to the second-dimension (4).



DTT preserves the fully reduced state of denatured, unalkylated proteins.



Sodium dodecyl sulfate (SDS) denatures proteins and forms negatively charged protein-SDS complexes. The amount of SDS bound to a protein, and therefore the additional negative charge, is directly proportional to the mass of the protein. Thus, electrophoresis of proteins through a sieving gel in the presence of SDS separates proteins on the basis of molecular mass.



Iodoacetamide alkylates thiol groups on proteins, preventing their reoxidation during electrophoresis. Protein reoxidation during electrophoresis can result in streaking and other artifacts. Iodoacetamide also alkylates residual DTT to prevent point streaking and other silver-staining artifacts (74). Iodoacetamide is introduced in a second equilibration step. This step is optional when SDS-PAGE is performed in a vertical second-dimension system, but required when SDS-PAGE is performed on a flatbed second-dimension system especially when the flatbed separation is to be visualized by silver staining. The second equilibration with iodoacetamide is also used to minimize unwanted reactions of cysteine residues (i.e. when mass spectrometry is to be performed on the separated proteins).



Tracking dye (bromophenol blue) allows monitoring of electrophoresis.

3.2.2 Equilibration steps



Note: The second-dimension vertical gel must be ready for use prior to IPG strip equilibration. See sections 3.3 and 3.4 for preparation of vertical and horizontal gels, respectively.

1. Prepare equilibration solution

Prepare SDS Equilibration buffer (see Appendix I, solution D). This is a stock solution. Just prior to use, add 100 mg DTT per 10 ml SDS equilibration buffer.

2. Equilibration

Place the IPG strips in individual tubes with the support film toward the wall. Add 10 ml of the DTT-containing solution to each tube. Cap the tube, and place it on its side on a rocker. Equilibrate for 15 min.

3. Second equilibration

A second equilibration may be performed with an iodoacetamide solution (without DTT). Prepare a solution of 250 mg iodoacetamide per 10 ml SDS equilibration buffer.

Note: This second equilibration step reduces point streaking and other artifacts.

Add 10 ml of solution per tube. Cap the tube, place it on its side on a rocker, and equilibrate for 15 min.

Equilibration of IPGstrips prior to SDS PAGE:

2% SDS, 50 mM Tris-HCl pH 8.8, 6 M urea, 30% (v/v) glycerol, 0.002% bromophenol blue

15 min 10 ml + 100 mg DTT

15 min 10 ml + 250 mg IAA



Tip: The subsequent steps of electrophoresis unit preparation, insertion of the gel into the precast gel cassette, and melting of the Sealing Solution can be performed as the IPG strips are equilibrating.

3.3 The Ettan DALTwelve system

The Ettan DALTwelve system is designed to handle up to 12 large, second-dimension gels (26 × 20 cm) in a simple, efficient, and reproducible manner (see Fig 6, page 11). Running fewer gels, unused slots are filled with the blank cassette inserts. Safety interlocks prevent the application of power to the separation unit unless the lid is closed properly and the pump valve is in the *circulate* position. The lid is easily removed for cleaning by sliding it off its hinges.

Turning the lever at the back of the unit from *circulate* to *drain* drains the tank. The temperature is controlled by Peltier modules attached to the heat exchanger beneath the tank.

Power Supply/Control Unit

The Ettan DALTwelve system is controlled from the Power Supply/Control Unit. The unit supplies a maximum power output of 200 W with a maximum of 600 V or 1 A. The temperature control range is 10–50 °C.

3.3.1 Preparation of Ettan DALT^{twelve} Separation Unit for electrophoresis

1. Prepare cathode buffer

Dilute the cathode buffer included in the Ettan DALT Buffer Kit to working strength by adding both bottles of 10x cathode buffer (total volume 250 ml) to 2.25 l distilled or deionized water.

2. Prepare anode buffer

Ensuring that the valve on the separation unit is set to "circulate", add the entire contents (75 ml) of the 100x anode buffer included in the Ettan DALT Buffer Kit into the tank. Fill the tank to the 7.5 l fill line with distilled or deionized water, in this way washing the 100x anode solution from the buffer seal.

3. Switch the separation unit on

4. Turn on the pump to mix, set separation unit to desired temperature

Note: Avoid pouring the 100x anode buffer onto the tubing by spreading the tubing elements apart using one hand while pouring the solution with the other (Fig 23).

Note: A temperature of 25 °C is recommended for electrophoresis.

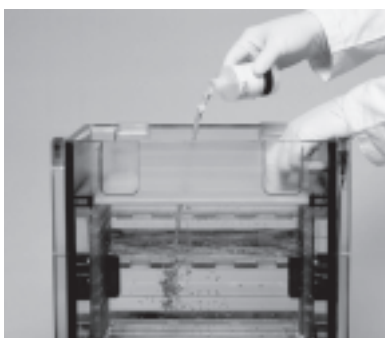

Fig 23. Avoid pouring the 100x anode buffer onto the tubing by spreading the tubing elements apart with one hand while pouring the solution with the other.

3.3.2 Ettan DALT precast gels

Ettan DALT Gel, 12.5 is a precast polyacrylamide gel for the second-dimension of two-dimensional electrophoresis. The gel is cast onto a plastic support film. The exact gel size is 255 × 196 × 1 mm. The gel is a homogeneous 12.5% polyacrylamide gel cross-linked with bisacrylamide. It is intended to be used in the Ettan DALT^{twelve} system together with the Ettan DALT Buffer Kit. The gel is formulated for long shelflife and, when used with the buffer kit, generates a discontinuous buffer system yielding rapid runs with sharp, reproducible results. The gels are inserted into a specially designed reusable cassette and run in a vertical mode in the Ettan DALT^{twelve} Separation Unit.

Inserting the Ettan DALT Gel, 12.5 into Ettan DALT Precast Gel Cassette

1. Open the gel package

Cut around the gel on two sides at about 1 cm from the edge to avoid cutting the gel or the support film. Remove the gel from the package. The gel is cast onto a plastic support film and does not cover the film entirely. The gel is covered with a protective plastic sheet. Markings on the protective sheet indicate the orientation of the gel and the direction of electrophoresis. The bottom (+ or anodic) edge of the gel is flush with the edge of the support film. The support film protrudes approximately 15 mm beyond the top (– or cathodic) edge of the gel and approximately 5 mm at either side.

2. Open an Ettan DALT Precast Gel Cassette

Place it on the bench top with the hinge down (see Fig 24). Apply 1 ml gel buffer onto the glass plate as a streak along the spacer on the right edge of the glass plate (see Fig 24).



Fig 24. An opened Ettan DALT Precast Gel Cassette showing plastic frame cover (left) and glass plate (right).

3. Remove the protective plastic sheet from the gel

Handling the gel only by the side support film margins, hold it (gel-side down) over the glass plate. Ensure that it is oriented with the cathodic (-) edge of the gel toward the cathodic (-) edge of the cassette. Align the right edge of the gel with the right edge of the side spacer of the glass plate side, flex the gel downward slightly and lower it slowly toward the glass plate from left to right. Take care that the bottom (anodic) edge of the gel is flush (within 1 mm) of the bottom (anodic) edge of the glass plate. The protruding side support film margins (but not the gel) should rest on top of the side spacers.

4. Removal of bubbles and excess buffer

Use the roller to press out any bubbles or liquid from between the gel and the glass. Press **firmly** against the plastic support film with the roller and roll over the entire gel (see Fig 25). After rolling, the gel should adhere firmly to the glass.

5. Close the cassette

Snap the plastic frame cover to the glass plate (see Fig 26) and press the edges tightly together. Ensure that the cassette is closed completely: an incompletely closed cassette causes a strongly curved front.

6. Repeat the procedure for each second-dimension gel to be run



Fig 25. Pressing out air pockets between gel and glass plate.



Fig 26. Closing the Precast Gel Cassette.

3.3.3 Equilibrate the IPG strip

(See section 3.2.2 for equilibration protocol)

3.3.4 Applying the equilibrated IPG strip

1. Position the IPG strip

Dip the equilibrated IPG strip (from section 3.2.2) in the SDS electrophoresis buffer (see Appendix I, solution J) to lubricate it.

Both types of Ettan DALT gel cassettes (those for lab-cast and for precast gels) have a "longer" glass plate. The cassette should be laid on the bench with the longer glass plate down, the protruding edge oriented towards the operator. Place the strip with the acidic end to the left, gel surface up onto the protruding edge of the longer glass plate (see Fig 27).

For other systems: Position the IPG strip between the plates on the surface of the second-dimension gel with the plastic backing against one of the glass plates (Fig 27). With a thin plastic ruler, gently push the IPG strip down so that the entire lower edge of the IPG strip is in contact with the top surface of the slab gel (Fig 28). Ensure that no air bubbles are trapped between the IPG strip and the slab gel surfaces or between the gel backing and the glass plate.

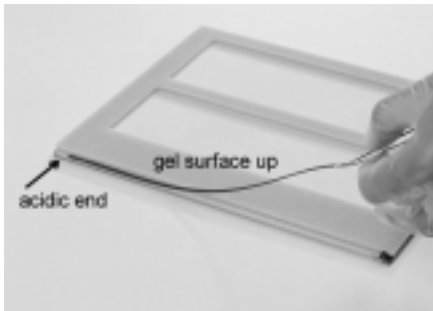

Fig 27. Positioning an equilibrated IPG strip on the Precast Gel Cassette.

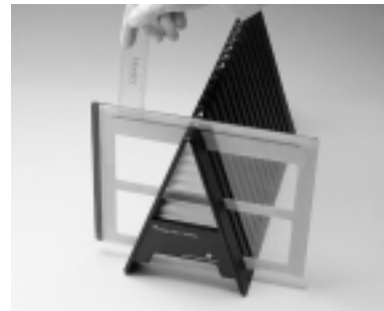

Fig 28. Pushing the IPG strip down to contact the gel slab.

2. Optional: Apply molecular weight marker proteins

Best results are obtained when the molecular weight marker protein solution is mixed with an equal volume of a hot 1% agarose solution prior to application to the IEF sample application piece. The resultant 0.5% agarose will gel and prevent the marker proteins from diffusing laterally prior to the application of electric current.

Other alternatives are to apply the markers to a paper IEF sample application piece in a volume of 15 to 20 μl . For less volume, cut the sample application piece proportionally. Place the IEF application piece on a glass plate and pipette the marker solution onto it, then pick up the application piece with forceps and apply to the top surface of the gel next to one end of the IPG strip. The markers should contain 200 to 1 000 ng of each component for Coomassie staining and about 10 to 50 ng of each component for silver staining.

3. Seal the IPG strip in place

For precast Ettan DALT gels, the agarose sealing has two functions:

1. Blockage of the narrow gap(s) between the gel edge(s) and the lateral spacer(s) to prevent leakage of the upper buffer.
2. Preventing the IPG strip from moving or floating in the electrophoresis buffer.

The second point is valid for all vertical systems.

Prepare agarose sealing solution for Ettan DALT precast gels using the agarose sealing solution from the Ettan DALT Buffer Kit. If using the Laemmli buffer system, see Appendix I, solution K.

Melt each aliquot as needed in a 100 °C heat block (each gel will require 1 to 1.5 ml). It takes approximately 10 min to fully melt the agarose. (Tip: An ideal time to carry out this step is during IPG strip equilibration).

Allow the agarose to cool until the tube can be held by fingers (60 °C) and then slowly pipette the amount required to seal the IPG strip in place (Fig 29). Pipetting slowly avoids introducing bubbles. Only apply the minimum quantity of agarose sealing solution required to cover the IPG strip. Allow a minimum of 1 min for the agarose to cool and solidify.

3.3.5 Insert the precast gel cassettes into the Ettan DALT*twelve* Separation Unit

1. Insert the gel cassettes (Fig 30)

When the electrophoresis buffer has reached the desired temperature, insert loaded gel cassettes (starting at the back of the separation unit) ensuring that the IPG strips are in place. Push blank cassette inserts into any unoccupied slots. When all 12 slots are occupied, the buffer level should be slightly below the level of the gaskets (0.5 cm).

If necessary, add distilled or deionized water to bring the level of the lower (anode) buffer to this level or drain any excess anode buffer that is in the upper chamber. The slight dilution of the anode buffer with extra distilled or deionized water will not affect the results.

Note: Cassette insertion is aided by spraying the gel cassettes with a mist of SDS electrophoresis buffer prior to insertion.

2. Pour diluted (1×) cathode buffer into the tank to the fill line

Note: Some of the diluted cathode buffer may drip through the gasket and mix with the anode buffer during the run. This mixing effect will not affect performance or results.

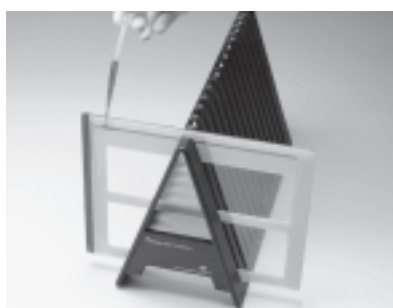

Fig 29. Sealing the IPG strip in place using treated agarose sealing solution.

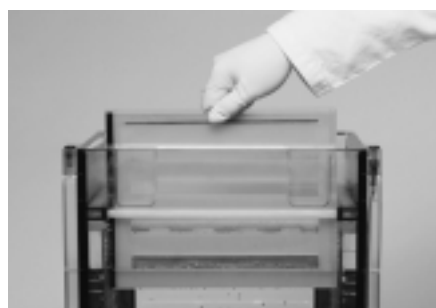

Fig 30. Inserting Precast Gel Cassettes into the Ettan DALT*twelve* Separation Unit.

3.3.6 Electrophoresis conditions

Table 20 lists the recommended conditions for the Hoefer miniVE, SE 260, SE 600, and Ettan DALT*twelve*. Electrophoresis is performed at constant current (or constant power for the Ettan DALT*twelve*) in two steps. During the initial migration and stacking period, the current is approximately half of the value required for the separation.

Stop electrophoresis when the dye front is approximately 1 mm from the bottom of the gel.

For the smaller systems cooling is optional. However, temperature control improves gel-to-gel reproducibility, especially if the ambient temperature of the laboratory fluctuates significantly.



Important: Do not cool SDS gels below 10 °C.

After electrophoresis, remove gels from their gel cassettes in preparation for staining or blotting. Notch or mark each gel* at the upper corner nearest the pointed end of the IPG strip to identify the acidic end of the first-dimension separation.

* If IPG strips have been applied correctly onto the precast Ettan DALT gels, this measure will not be necessary as the gels are cast on a support film.

Table 20. Recommended electrophoresis conditions for second-dimension vertical gels

	Step	Current (mA/gel)	Power (W/gel)	Duration (h:min)
Hoefer miniVE or SE 260				
1.5 mm-thick gels	1	15		0:15
	2	30		1:30*
1.0 mm-thick gels	1	10		0:15
	2	20		1:30*
Hoefer SE 600				
1.5 mm-thick gels	1	15		0:15
	2	30 [†]		5:00*
1.0 mm-thick gels	1	10		0:15
	2	20 [†]		5:00*
Ettan DALTwelve (set temperature to 25 °C)				
1 mm-thick gels (lab-cast and precast)	1		2.5	0:30
	2		17 (max 180)	4:30

* The time shown is approximate. Stop electrophoresis when the dye front is 1 mm from the bottom of the gel.

[†] Currents up to 50% higher may be used if only two gels per unit are being run (no divider plates) and the unit is being cooled with a thermostatic circulator.



3.3.7 Preparing SDS slab gels—vertical systems

The acrylamide, TEMED, ammonium persulfate, and SDS used in this protocol are extremely hazardous. You should have a manufacturer's safety data sheet (MSDS) detailing the properties and precautions for all chemicals in your lab. The safety sheets should be reviewed prior to starting the procedures in this manual. General handling procedures for hazardous chemicals include using double latex gloves for all protocols. Hazardous materials should be weighed in a fume hood while wearing a disposable dust mask.

The instructions provided below for the preparation of vertical SDS-polyacrylamide gels employ the tris-glycine system of Laemmli (72). Vertical second-dimension gels are most conveniently cast several at a time, in a multiple gel caster (see Ordering information). For assembly of the gel cassette, refer to the relevant User Manual.

1. Select the gel percentage

a. Single percentage gel versus gradient gel. When a gradient gel is used, the overall separation interval is wider and the linear separation interval is larger. In addition, sharper bands result because the decreasing pore size functions to minimize diffusion. However, a gradient gel requires more skill to cast. For detailed instructions on gradient preparation see the instruction manual for the relevant gel unit and multiple gel caster.

Single percentage gels offer better resolution for a particular M_r window. A commonly used second-dimension gel for 2-D electrophoresis is a homogeneous gel containing 12.5% total acrylamide.

Note: Stacking gels are not necessary for vertical 2-D gels.

b. Whether single percentage or gradient, the appropriate percentage gel is selected according to the range of separation desired (see Table 21).

Table 21. Recommended acrylamide concentrations for protein separation

% Acrylamide in resolving gel	Separation size range ($M_r \times 10^{-3}$)	
Single percentage:	5%	36–200
	7.5%	24–200
	10%	14–200
	12.5%	14–100*
	15%	14–60*
Gradient:	5–15%	14–200
	5–20%	10–200
	10–20%	10–150

* Larger proteins fail to move significantly into the gel.

2. Prepare the gel solution

The total volume of solution needed depends on the gel size, the gel thickness, and the number of gels cast. Table 22 gives volumes of gel solution required per gel for the various possible vertical gel formats.

3. Select gel thickness for Hoefer SE 600, MiniVE, or SE 260 electrophoresis systems

Either 1.0 or 1.5 mm-thick spacers can be used for all the smaller vertical formats. Thinner gels stain and destain more quickly and generally give less background staining. Thicker gels have a higher protein capacity. Thicker gels are also less fragile and easier to handle.

Table 22. Volumes required per vertical gel

Casting system	Volume (ml)
Hoefer miniVE or SE 260 (10 × 10.5 cm plates)	
1 mm-thick spacers	10
1.5 mm-thick spacers	15
Hoefer SE 600 (18 × 16 cm plates)	
2 cm-wide × 1 mm-thick spacers	30
2 cm-wide × 1.5 mm-thick spacers	40
1 cm-wide × 1 mm-thick spacers	30
1 cm-wide × 1.5 mm-thick spacers	45

4. Calculate the formulation of the gel solution

The recipes given in Table 23 produce 100 ml of solution for a single percentage gel. The recipes in Table 24 produce 50 ml each of light and heavy solution for a gradient gel. These recipes are to be scaled up or down, depending on the volume required.

5. Prepare the gel solution

Gel solution is prepared in a vacuum flask, omitting the TEMED and ammonium persulfate. Add a small magnetic stir bar. Stopper the flask and apply a vacuum for several min while stirring on a magnetic stirrer.

Add the TEMED and ammonium persulfate and gently swirl the flask to mix, being careful not to generate bubbles. Immediately pour the gel.

6. Pour and prepare the gel

Fill the gel cassette to 3 to 10 mm below the top (no stacking gel layer is required).

Overlay each gel with a layer of water-saturated *n*-, *i*-, or *t*-butanol (3 ml) immediately after pouring to minimize gel exposure to oxygen and to create a flat gel surface.

After allowing a minimum of 1 h for polymerization, remove the overlay and rinse the gel surface with gel storage solution (see Appendix I, solution I).

7. Storage of unused gels

Gels not used immediately can be stored for future use at 4 °C for up to two weeks. Gel storage solution (see Appendix I, solution I) is pipetted over the top gel surface and the gel cassette is sealed with flexible paraffin film. Alternatively, the gel cassettes can be stored fully immersed in gel storage solution.

Note: For further information on the preparation of second-dimension vertical SDS slab gels, refer to the user manuals for the respective vertical gel unit and multiple gel caster.

Table 23. Single-percentage gel recipes (preparation of stock solutions is described in Appendix I, solutions E, F, G, and H)

Final Gel Concentration	5%	7.5%	10%	12.5%	15%
Monomer solution (solution E)	16.7 ml	25 ml	33.3 ml	41.7 ml	50 ml
4× resolving gel buffer (Solution F)	25 ml	25 ml	25 ml	25 ml	25 ml
10% SDS (Solution G)	1 ml	1 ml	1 ml	1 ml	1 ml
Double distilled water	56.8 ml	48.5 ml	40.2 ml	31.8 ml	23.5 ml
10% ammonium persulfate* (Solution H)	500 µl	500 µl	500 µl	500 µl	500 µl
TEMED*	33 µl	33 µl	33 µl	33 µl	33 µl
Total volume	100 ml	100 ml	100 ml	100 ml	100 ml

* Add after deaeration.

Table 24. Recipes for gradient gels (preparation of stock solutions is described in Appendix I, solutions E, F, G, and H)

Light solution - Final Concentration	5%	7.5%	10%	12.5%	15%
Monomer solution (solution E)	8.4 ml	12.5 ml	16.5 ml	21.0 ml	25 ml
4x resolving gel buffer (Solution F)	12.5 ml	12.5 ml	12.5 ml	12.5 ml	12.5 ml
10% SDS (Solution G)	500 µl	500 µl	500 µl	500 µl	500 µl
Double distilled water	28.5 ml	24.5 ml	20.0 ml	16.0 ml	12.0 ml
10% ammonium persulfate* (Solution H)	170 µl	170 µl	170 µl	170 µl	170 µl
TEMED*	17 µl	17 µl	17 µl	17 µl	17 µl
Total volume	50 ml	50 ml	50 ml	50 ml	50 ml
Heavy solution - Final Concentration	10%	12.5%	15%	17.5%	20%
Monomer solution (solution E)	16.7 ml	21.0 ml	25.0 ml	29.2 ml	33.3 ml
4x resolving gel buffer (Solution F)	12.5 ml	12.5 ml	12.5 ml	12.5 ml	12.5 ml
Sucrose	7.5 g	7.5 g	7.5 g	7.5 g	7.5 g
10% SDS (Solution G)	500 µl	500 µl	500 µl	500 µl	500 µl
Double distilled water	16.2 ml	11.7 ml	7.7 ml	3.5 ml	0 ml
10% ammonium persulfate* (Solution H)	165 µl	165 µl	165 µl	165 µl	165 µl
TEMED*	16.5 µl	16.5 µl	16.5 µl	16.5 µl	16.5 µl
Total volume	50 ml	50 ml	50 ml	50 ml	50 ml

* Add after deaeration.

3.3.8 Troubleshooting



Table 25 lists possible problems that could be encountered during vertical SDS-PAGE and how to solve them.

Table 25. Troubleshooting vertical second-dimension SDS-PAGE

Symptom	Possible cause	Remedy
No current at start of run	Insufficient volume of buffer in upper or lower reservoir.	Ensure that both reservoirs contain enough SDS electrophoresis buffer to contact both upper and lower electrode wires. Check for leaks.
Second-dimension separation proceeds too slowly	SDS electrophoresis buffer prepared incorrectly, or, resolving gel buffer prepared incorrectly.	Make fresh solutions.
	Acrylamide solution is too old.	Prepare fresh monomer stock solution.
Dye front curves up (smiles) at the edges	Gel is not properly cooled.	During electrophoresis, actively cool gel using a thermostatic circulator. Use the maximum possible volume of buffer in the lower reservoir.
	Current or power too high.	Limit current or power to values suggested in Table 20.
Dye front curves down (frowns)	Gel is poorly polymerized near the spacers.	Degas the gel solution, or increase the amount of ammonium persulfate and TEMED by 50%.
	Improper instrument assembly (SE 600).	Ensure that the gasket is not pinched.
	Leakage of upper reservoir	Ensure that an adequate level of buffer is in the upper reservoir.

continues on following page

Table 25. Troubleshooting vertical second-dimension SDS-PAGE (continued)

Symptom	Possible cause	Remedy
Second-dimension separation proceeds slowly with high current	All of the slots in the sealing assembly are not occupied by either gel cassettes or blank cassettes.	Ensure that all 12 slots in the sealing assembly are occupied.
	Anodic buffer has mixed with cathodic buffer from overfilling of either the cathodic reservoir or the anodic reservoir.	Do not pour more than the suggested volume (7.5 l) into the lower reservoir. Ensure that the level of the anode buffer does not come above the sealing assembly when the electrophoresis unit is fully loaded. If excess anode buffer is in the upper reservoir, it should be removed with a pipette. Ensure that the level of cathode buffer does not come above the air vents in the corners of the upper reservoir. Lack of mixing between upper and lower reservoirs can be verified by adding bromophenol blue dye to the lower reservoir prior to loading the unit with gels. Several drops of 1% (w/v) bromophenol blue will impart sufficient color to the anode buffer.
Dye front is irregular	Poor, uneven polymerization of gel.	Degas the gel solution, or increase the amount of ammonium persulfate and TEMED by 50%.
	The top surface of the second-dimension gel is not flat.	Immediately after pouring the gel, overlay the surface with water-saturated butanol.
	The top surface of the gel has been damaged during application of the IPG strip.	Take care during application of the IPG strip that the gel is not damaged.
	Bubbles between the gel and the glass plate.	Use the roller to remove any bubbles or excess liquid between the gel and the glass plate.
	Liquid between the gel and the glass plate.	Ensure that no visible bubbles remain and that the gel adheres firmly to the glass and resists movement.
Pronounced downward curving of the dye front on one side of the gel	Interfering substances in the first-dimension.	Contaminants in the sample can cause distortions or swollen regions in the IPG strip following IEF. These distortions can result in turn in disturbances in the second-dimension. Modify sample preparation to limit these contaminants.
	There is an unfilled gap between the gel and one of the spacers.	When sealing the IPG strip into place on top of the gel, ensure that some of the sealing solution flows down any gap that may exist between the gel and spacer.
	Precast gel cassette(s) not properly closed.	Ensure cassette(s) are properly closed and repeat the run.
Distortion in the 2-D pattern	Bubbles between the gel and the glass plate.	Use the roller to remove any bubbles or excess liquid between the gel and the glass plate. Ensure that no visible bubbles remain and that the gel adheres firmly to the glass and resists movement.
	Liquid between the gel and the glass plate.	Use the roller to remove any bubbles or excess liquid between the gel and the glass plate. Ensure that no visible bubbles remain and that the gel adheres firmly to the glass and resists movement.
	Interfering substances in the first-dimension.	Contaminants in the sample can cause distortions or swollen regions in the IPG strip following IEF. These distortions can result in turn in disturbances in the second-dimension. Modify sample preparation to limit these contaminants.
Vertical gap in the 2-D pattern	Bubble between IPG strip and top surface of second-dimension gel.	Ensure that no bubbles are trapped between the IPG strip and the top surface of second-dimension gel.

continues on following page

Table 25. Troubleshooting vertical second-dimension SDS-PAGE (continued)

Symptom	Possible cause	Remedy
Vertical streaking	Incorrectly prepared equilibration solution.	Prepare equilibration solution according to instructions.
	Poor transfer of protein from IPG strip to second-dimension gel.	Employ a low power or current sample entry phase in the second-dimension electrophoresis run. Prolong entry phase if necessary.
	Insufficient equilibration.	Prolong equilibration time.
Spots are vertically doubled, or "twinned".	IPG strip is not placed properly.	Ensure that the plastic backing of the IPG strip is against the glass plate of the second-dimension cassette.
Poor representation of higher molecular weight proteins	Incorrectly prepared equilibration solution.	Prepare equilibration solution according to instructions.
	Poor transfer of protein from IPG strip to second-dimension gel.	Employ a low power or current sample entry phase in the second-dimension electrophoresis run. Prolong entry phase if necessary.

3.4 Multiphor II flatbed system

3.4.1 ExcelGel preparation

Two sizes of precast ExcelGel gradient SDS gels are recommended for 2-D electrophoresis: the 110 × 250 mm gel homogeneous 12.5% and the 180 × 250 mm gel, which contains a 12–14% acrylamide gradient. Either gel accepts a single 24, 18, or 13 cm IPG strip, two 11 cm, or three 7 cm IPG strips. Placing shorter IPG strips end-to-end is ideal for comparative studies. For maximum resolution, the larger gel coupled with the 24 cm or 18 cm IPG strip is the best choice. Using the buffer strip positioner helps to get optimal results: good reproducibility is achieved because of standardized placement of IPG strips and buffer strips, and a straight run because the gel surface is covered.



Important: A flatbed second-dimension system is not recommended if the first dimension has been run on a pH 6–11 IPG strip.

1. Equilibrate the IPG strips

During the preparation of the ExcelGel SDS gel, equilibrate the IPG strips as described in section 3.2.2.

2. Prepare the Multiphor II Electrophoresis Unit

Set the temperature on the MultiTemp III Thermostatic Circulator to 15 °C. Pipette 2.5 to 3.0 ml of kerosene onto the Multiphor II cooling plate.

3. Position the ExcelGel SDS gel

Remove the gel from the foil package by cutting away the edges of the package. A notch at the lower lefthand corner of the film identifies the 12.5% or 14% (i.e., anodic) end.



Note: The gel is cast on a plastic support film and does not cover the film entirely. Both gel types contain a stacking gel zone with 5% acrylamide. Markings on the plastic cover indicate the direction of electrophoresis. Orient the gel according to these markings, remove the cover, and place the gel on the cooling plate. The cathodic edge of the ExcelGel SDS must align and make uniform contact with the cathodic edge of the grid on the cooling plate.



Note: Avoid trapping bubbles between the gel and the cooling plate. Avoid getting DryStrip Cover Fluid or kerosene on the gel surface as this may cause the buffer strips to slide during electrophoresis.

Separation quality is improved if the gel surface is allowed to dry, uncovered, for about min 5 min before proceeding.

4. Place the Multiphor II Buffer Strip Positioner

The pegs protruding from the bottom of the positioner should be in contact with the shorter sides of the cooling plate. Match the cathode (–) and anode (+) symbols on the positioner to the cathode and anode symbols on the cooling plate. Slide the positioner so that the cathodic (–) edge of the gel bisects the slot at position 1 (see instruction for Multiphor II Buffer Strip Positioner). Lock the positioner in place by turning the grey locking cam until the positioner cannot be moved.

5. Position the cathodic buffer strip (Fig 31)

Carefully peel back the foil on the colorless cathodic (–) ExcelGel SDS buffer strip. Place the buffer strip with the smooth, narrow face downward. Align the buffer strip with the edge of the slot at position 1 and place it in the slot. If the buffer strip breaks, piece it together on the gel.

Note: Vinyl gloves tend to stick less to the buffer strips than other types of plastic gloves. If sticking persists, dampen the gloves with distilled water or a 5% SDS solution.

6. Position the anodic buffer strip

Carefully peel back the foil on the yellow-colored (+) anodic strip and place it in the appropriate slot of the positioner:

For 11 × 25 cm ExcelGel SDS gels, place the anodic strip in slot 3, in the center of the positioner.

For 18 × 25 cm ExcelGel SDS gels, place the anodic strip in slot 4, anodic edge (+) of the positioner.

The buffer strips should sit snugly within the slots.

3.4.2 Applying the equilibrated IPG strip

(See section 3.2.2 for the equilibration protocol).

1. Drain moisture from IPG strips (flatbed second-dimension only)

After equilibration, place the IPG strips on filter paper moistened with deionized water. To help drain the equilibration solution, place the IPG strips so they rest on an edge. IPG strips can be left in this position for up to 10 min without noticeably affecting the spot sharpness. Alternatively, the IPG strips can be gently blotted with moistened filter paper to remove excess equilibration buffer.

2. Position the IPG strip(s) (Fig 32)

Once the equilibrated IPG strips (from section 3.2.2) have drained for at least 3 min, place the IPG strips, using forceps, gel-side down on the ExcelGel through the slot at position 2.

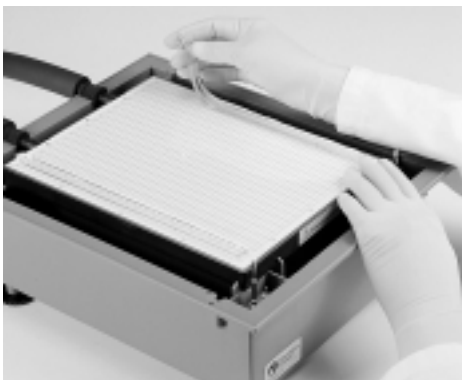

Fig 31. Positioning the cathodic buffer strip on Multiphor II.

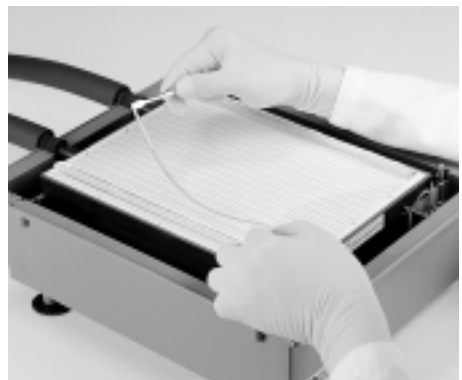

Fig 32. Positioning equilibrated IPG strips on Multiphor II.

3. Position sample application pieces (Fig 33)

Using forceps place one IEF sample application piece at the end of each IPG strip underneath the plastic "tab" formed by the overhanging gel support film at each end of the IPG strip. Be sure the application pieces touch the ends of the IPG strip.

Note: Application pieces absorb water that flows out of the IPG strips during electrophoresis.

4. Ensure contact between IPG strip and ExcelGel

Make sure that the IPG strip is in full, direct contact with the SDS gel. To remove any bubbles, stroke the plastic backing of the IPG strip gently with a spatula or forceps.

5. Optional: Apply molecular weight marker proteins

If loading marker proteins, place an extra application piece on the surface of the gel just beyond the end of the IPG strip. Pipette the markers onto the extra sample application piece. Apply the markers in a volume of 15 to 20 μ l. For less volume, cut the sample application piece proportionally. The markers should contain 200 to 1 000 ng of each component for Coomassie staining and about 10 to 50 ng of each component for silver staining.

6. Position electrodes (Fig 34)

Place the IEF electrode holder on the electrophoresis unit, in the upper position, and align the electrodes with the center of the buffer strips. Plug in the electrode connectors and carefully lower the electrode holder onto the buffer strips.

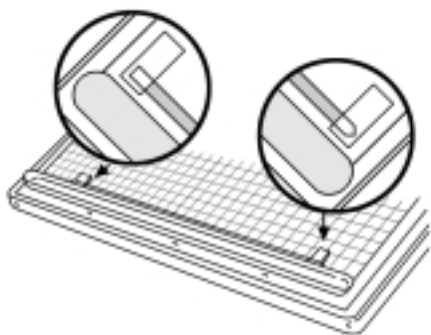

Fig 33. Positioning of application pieces.



Fig 34. Positioning electrodes.

3.4.3 Electrophoresis conditions

Place the safety lid on the Multiphor II. Connect the power supply. Recommended electrical settings and running times are listed in Table 26.

Table 26. Electrophoresis conditions for ExcelGel

	Step	Voltage(V)	Current (mA)	Power (W)	Duration (h:min)
ExcelGel SDS, 12.5 %	1	120	20	30	0:40
	2	600	50	30	1:10 [†]
ExcelGel XL SDS, gradient, 12–14%	1	200	20	20	0:40
	2	800	40	40	2:40 [†]

* Remove the IPG strip and the application pieces. Then move the cathodic buffer strip forward to cover the area of the removed IPG strip. Adjust the position of the cathodic electrode.

[†] Electrophoresis is stopped 5 min after the bromophenol blue front has just reached the anodic buffer strip. Remove and discard the buffer strips.



3.4.4 Troubleshooting

Table 27 lists possible problems that could be encountered during second-dimension SDS-PAGE using the Multiphor II flatbed system and how to solve them.

Table 27. Troubleshooting second-dimension SDS-PAGE: Multiphor II flatbed system

Symptom	Possible cause	Remedy
No current at start of run	The electrode cable is not plugged in.	Ensure that all cables are properly connected.
Dye front curves up (smiles) at one edge	Cathodic buffer strip does not contact the gel at the one edge.	Ensure that the cathodic buffer strip is centered and covers the entire width of the second-dimension gel.
Dye front curves up (smiles) at both edges	Inadequate cooling.	Ensure that the thermostatic circulator is connected to the Multiphor II Electrophoresis Unit and functioning correctly.
Dye front is irregular	Some dye front irregularity results from the use of IPG Buffer and does not affect results.	Ensure that the expiration dates on the buffer strips and ExcelGel have not elapsed.
	Buffer strips or ExcelGel are old.	
	Bubbles under the buffer strip.	
	Bubbles under the IPG strip.	Ensure that the IPG strip is placed firmly on the gel with no air bubbles trapped underneath. Stroke the plastic backing of the IPG strip gently with a pair of forceps to remove trapped bubbles.
Buffer strip slides out from under the electrode	Incorrect electrode placement.	Ensure that the electrodes are aligned over the center of the buffer strips before lowering the electrode holder.

Chapter 4

Visualization and evaluation of results

4.0 Visualization of results

Most detection methods used for SDS gels can be applied to second-dimension gels. The following features are desired:

- High sensitivity
- Wide linear range for quantification
- Compatibility with mass spectrometry
- Low toxicity and environmentally safe
- Environmentally friendly

However, because none of the existing techniques can meet all these requirements, a 2-D electrophoresis laboratory may need to have more than one of the following methods in its repertoire:

Autoradiography and *fluorography* are the most sensitive detection methods (down to 200 fg protein). To employ these techniques, the sample must consist of protein radiolabelled *in vivo* using either ^{35}S , ^{14}C , ^3H or, in the case of phosphoproteins, ^{32}P . For autoradiographic detection, the gel is simply dried and exposed to X-ray film or—for quicker results and superior dynamic range of quantification—to a storage phosphor screen. Fluorography is a technique that provides extra sensitivity by impregnating the gel in a scintillant such as PPO (2,4-diphenyloxazole) prior to drying.

Silver staining is the most sensitive non-radioactive method (below 1 ng). Silver staining is a complex, multi-step process utilizing numerous reagents for which quality is critical. It is therefore often advantageous to purchase these reagents in the form of a dedicated kit, in which the reagents are quality assured specifically for the silver-staining application. The PlusOne™ Silver Staining Kit, Protein combines superior sensitivity with ease of use.

By omitting glutardialdehyde from the sensitizer and formaldehyde from the silver nitrate solution the method becomes compatible with mass spectrometry analysis (75), however at the expense of sensitivity.

When staining Ettan Dalt precast gels with PlusOne™ Silver Staining Kit, Protein, a modified staining protocol should be used. For details of the modified protocol, see Appendix II—Optimized silver staining of precast DALT gels using PlusOne Silver Staining Kit, Protein.

Coomassie staining, although 50- to 100-fold less sensitive than silver staining, is a relatively simple method and more quantitative than silver staining. Coomassie blue is preferable when relative amounts of protein are to be determined by densitometry. Colloidal staining methods are recommended, because they show the highest sensitivity, down to 100 ng/protein spot (76).

Hoefer Processor Plus automates multistep staining processes for increased convenience and reproducibility. Automated protocols were developed to use the PlusOne Silver Staining Kit, Protein to silver stain proteins in SDS gels. This convenient adaptation gives reproducible results and sensitivity below 1 ng per spot for most proteins. With a modification for subsequent mass spectrometry, detection down to approx. 5 ng per spot can be achieved (77). For complete details, please refer to the Hoefer Processor Plus Protocol Guide.

The *Staining Tray Set* provides a convenient means of staining up to 4 large-format gels at a time—film-backed, as well as unbacked. The set includes two stainless steel trays and a perforated stainless steel tray, which seats within the staining trays, and a transparent plastic cover. The perforated insert supports and restrains gels for transfer between staining trays while allowing staining solution to drain rapidly.

Negative Zinc--Imidazole staining has a detection limit of approx. 15 ng protein/spot (78) and is well compatible with mass spectrometry, but it is a poor quantification technique.

Fluorescent labelling (79) and *fluorescent staining* with SYPRO™ dyes (80–83) have a sensitivity in-between colloidal Coomassie and modified PlusOne Silver Staining Kit, Protein staining (77). These techniques require fluorescence scanners, but they are compatible with mass spectrometry and show a wide dynamic range for quantification.

Preserving the gels: The film-supported Ettan DALT and ExcelGel gels are optimally stored in sheet protectors after soaking them in 10% v/v glycerol for 30 min. Unbacked gels are shrunk back to their original sizes by soaking them in 30% (v/v) methanol or ethanol/4% glycerol until they match their original sizes. For autoradiography the gels are dried onto strong filter paper with a vacuum drier or in-between two sheets of wet cellophane locked in Easy Breeze™ drying frames.

4.1 Blotting

Second-dimension gels can be blotted onto a nitrocellulose or PVDF membrane for immunochemical detection of specific proteins or chemical microsequencing.



Note: The plastic backing on Ettan DALT and ExcelGel precast gels is removed with the Film Remover prior to electrotransfer (see Ordering Information).

4.2 Evaluation

In theory, the analysis of up to 15 000 proteins should be possible in one gel; in practice, however, 5 000 detected protein spots means a very good separation. Evaluating high-resolution 2-D gels by a manual comparison of two gels is not always possible. In large studies with patterns containing several thousand spots, it may be almost impossible to detect the appearance of a few new spots or the disappearance of single spots. Image collection hardware and image evaluation software are necessary to detect these differences as well as to obtain maximum information from the gel patterns.

Amersham Biosciences ImageMaster™ 2D Elite Software and 2D Database Software, as well as Ettan Progenesis software together with ImageScanner™ and/or Typhoon™

multicolor fluorescence and phosphor image scanner comprise a system that allows the user to capture, store, evaluate, and present information contained in 2-D gels:

- The ImageScanner desktop instrument captures optical information in the visible wavelength range over a range from 0 to more than 3.4 O.D. in reflection or transmission mode. It scans 20 × 20 cm in 40 s at 300 dpi.
- Typhoon 8600 and 9200 series variable mode imagers have two excitation sources for fluorescence imaging; a green (532 nm) and a red (633 nm) laser. Typhoon 9400 series imager has an additional blue laser with two excitation lines (457 nm and 488 nm). Typhoon series imagers can be used for high-performance 4-color automated fluorescence detection, storage phosphor imaging, and chemiluminescence. Comprehensive information on fluorescence imaging can be found in the Amersham Biosciences handbook: *Fluorescence Imaging, principles and methods* (63-0035-28).
- ImageMaster 2D Elite provides the essential tools for analyzing complex protein samples separated by 2-D electrophoresis. Protein spots are automatically detected, background is corrected, spot density is quantified, and spots are matched between up to 100 gels. The software can also detect and graphically display quantitative changes in spot patterns.
- ImageMaster 2D Database software adds a database search facility that searches and queries across experiments and images, and analyzes experiments for quantitative pattern relationships.
- Ettan Progenesis is a high-throughput, fully automated 2-D imaging software for parameter-free spot detection. No manual spot editing is required, resulting in maximum reproducibility of evaluation results. Its automated parameter-free warping drives spot matching between different gels, providing a 3-D view of spots. Batch processing of all spot detection, background removal, gel warping, gel averaging, and spot matching improves speed of routine analysis.

4.3 Standardization of results

The 2-D electrophoresis technique is often used comparatively, and thus requires a reproducible method for determining relative spot positions. Because precast Immobiline DryStrip gels are highly reproducible, the pI of a particular protein can be estimated from its focusing position along a linear pH gradient IPG strip. Detailed information on Immobiline DryStrip pH gradients are found in the Amersham Biosciences brochure: *Immobiline DryStrip visualization of pH gradients* (18-1140-60).

The second-dimension can be calibrated using molecular weight marker proteins loaded to the side of the second-dimension gel. Often, there are abundant proteins in the sample for which the pI and molecular weight are known. These proteins can serve as internal standards.



Note: The pI of a protein can depend on its chemical environment and thus can differ depending on the experimental conditions used. Although marker proteins for pI estimation are available, pI estimates based on their use are not necessarily valid.

4.4 Further analysis of protein spots

4.4.1 Picking the spots

The Ettan Spot picker is a robotic system that automatically picks selected protein spots from stained or destained gels using a pick list from the image analysis, and transfers them into microplates.

Ettan DALT or ExcelGel precast gels on film supports or lab-cast gels on glass or plastic films are stained with Coomassie, silver, or fluorescent dyes and two visible reference markers are pasted on each gel. The gels are scanned using ImageScanner or Typhoon and analyzed using ImageMaster 2D Elite or Ettan Progenesis software. The positions of selected protein spots are exported as a pick list to the Ettan Spot Picker. The gels are placed into the instrument under liquid, the camera detects the reference markers. Control software converts spot pixel co-ordinates into picking co-ordinates, and the Ettan Spot Picker selects and transfers gel plugs into 96-well microplates.

4.4.2 Digestion of the proteins

The gel plugs are automatically digested in the Ettan Digester, the supernatant peptides are mixed with MALDI matrix material and spotted onto MALDI slides using Ettan Spotter.

This spot handling procedure can either be performed fully automatically in the integrated Ettan Spot Handling Workstation or semi-automatically by manual transfer of gels and microplates between these instruments as stand-alone units.

4.4.3 MALDI-ToF mass spectrometry

In the Ettan MALDI-ToF mass spectrometer, a laser beam is fired into the dried peptide-matrix spots for ionization of the peptides. After accurate determination of the peptide masses, databases are searched for identification of the original proteins. Ettan MALDI-ToF utilizes an advanced quadratic field reflectron (Z^2 reflectron) for automatic protein identification by peptide mass fingerprinting. The Z^2 reflectron also allows *de novo* sequencing of peptides by post-source decay.

Chapter 5

Troubleshooting

5.0 Troubleshooting 2-D results

Table 28 lists problems that may be encountered in 2-D electrophoresis results, describes the possible causes, and suggests ways to prevent problems in future experiments. For troubleshooting problems encountered during the various steps of the 2-D process, refer to the following Tables:

- Table 12, page 36. Troubleshooting IPG strip rehydration in Reswelling Tray.
- Table 14, page 43. Troubleshooting first-dimension IEF: Multiphor II and Immobiline DryStrip Kit.
- Table 19, page 55. Troubleshooting first-dimension IEF: IPGphor.
- Table 25, page 66. Troubleshooting vertical second-dimension SDS-PAGE.
- Table 27, page 71. Troubleshooting second-dimension SDS: Multiphor II flatbed system.

Table 28. Troubleshooting 2-D results

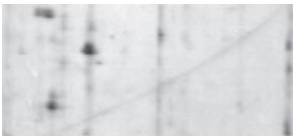
Symptom	Possible cause	Remedy
No distinct spots are visible 	Sample is insufficient.	Increase the amount of sample applied.
	Insufficient sample entered the IPG strip due to poor sample solubilization.	Increase the concentration of the solubilizing components in the sample solution. (See section 1.5, 'Composition of sample solution.')
	Sample contains impurities that prevent focusing.	Increase the focusing time or modify the sample preparation method. (See 'Chapter I, Sample Preparation.')
	The pH gradient is wrongly oriented.	The pointed end of the Immobiline DryStrip is the acidic end and should point toward the anode (+).
	(Flatbed gel format) IPG strip is placed wrong side down on second-dimension gel.	Ensure that the IPG strip is placed gel-side down (plastic backing upward) on the SDS second-dimension gel.
	Detection method was not sensitive enough.	Use another detection method (e.g., silver staining instead of Coomassie blue staining).
	Failure of detection reagents.	Check expiry dates on staining solutions. Prepare fresh staining solutions.
Individual proteins appear as multiple spots or are missing, unclear, or in the wrong position	Protein carbamylation.	Do not heat any solutions containing urea above 30 °C, as cyanate, a urea degradation product, will carbamylate proteins, changing their pI.
	Protein oxidation.	DTT in the rehydration and equilibration solutions keeps the disulfide bonds reduced. For additional protection include an iodoacetamide treatment during equilibration prior to the second-dimension separation. Iodoacetamide alkylates the thiol groups to prevent the reduced proteins from reoxidizing.



continues on following page

Table 28. Troubleshooting 2-D results (continued)

Symptom	Possible cause	Remedy
<p>Spots are vertically doubled, or "twinning"</p> 	<p>(Vertical gel format) IPG strip is not placed properly.</p>	<p>Ensure that the plastic backing of the IPG strip is against the glass plate on the second-dimension gel.</p>
<p>Distortion of 2-D pattern</p> 	<p>(Vertical gel format) The top surface of the second-dimension gel is not flat.</p>	<p>Immediately after pouring the gel, overlay the surface with water-saturated butanol.</p>
	<p>(Vertical gel format) Uneven polymerization of gel due to incomplete polymerization, too rapid polymerization, or leakage during gel casting.</p>	<p>Degas the gel solution.</p> <p>Polymerization can be accelerated by increasing by 50% the amount of ammonium persulfate and TEMED used. Polymerization can be slowed by decreasing by 33% the amount of ammonium persulfate and TEMED used.</p> <p>Ensure that there is no leakage during gel casting.</p>
	<p>(Flatbed gel format) Moisture on the surface of the second-dimension gel.</p>	<p>Allow ExcelGel to dry for about 5 min after removing plastic cover and before applying buffer strips and IPG strip.</p>
	<p>(Flatbed gel format) IPG strip not removed during electrophoresis.</p>	<p>Remove the IPG strip and application pieces from the second-dimension gel when the bromophenol blue dye front has moved away from the IPG strip by 4–6 mm.</p>
	<p>(Flatbed gel format) Air bubbles under the second-dimension gel cause uneven migration due to poor heat transfer.</p>	<p>Ensure that no bubbles are trapped under the second-dimension gel during placement on the cooling plate.</p>
	<p>(Flatbed gel format) Water drops or pieces of buffer strip on the surface of the second dimension gel.</p>	<p>Take care that nothing is dropped or splashed onto the surface of the second-dimension gel.</p>

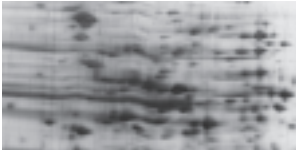

continues on following page

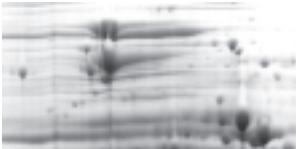
Table 28. Troubleshooting 2-D results (continued)

Symptom	Possible cause	Remedy
Horizontal streaking or incompletely focused spots 	Sample not completely solubilized prior to application.	<p>Be sure that the sample is completely and stably solubilized.</p> <p><i>Note:</i> Repeated precipitation-resolubilization cycles produce or increase horizontal streaking.</p> <p>See section 1.5, 'Composition of the sample solution,' for general guidelines for sample solubilization.</p>
	Sample is poorly soluble in rehydration solution.	<p>Increase the concentration of the solubilizing components in the rehydration solution. (See section 2.4, 'IPG strip rehydration solution.')</p> <p>Increase concentration of IPG Buffer.</p>
	<p>Interfering substances.</p> <p>Non-protein impurities in the sample can interfere with IEF, causing horizontal streaking in the final 2-D result, particularly toward the acidic side of the gel.</p>	<p>Modify sample preparation to limit these contaminants. (See section 1.4, 'Removal of contaminants that affect 2-D results.')</p>
	Ionic impurities in sample.	<p>Reduce salt concentration to below 10 mM by dilution or desalt the sample by dialysis. Precipitation with TCA and acetone and subsequent resuspension is another effective desalting technique that removes lipids, nucleotides, and other small molecules.</p> <p><i>Note:</i> Specific and non-specific losses of proteins can occur with dialysis, gel chromatography, and precipitation/resuspension of samples.</p> <p>If the sample preparation cannot be modified, the effect of ionic impurities can be reduced by modifying the IEF protocol. Limit the voltage to 100–150 V for 2 h, then resume a normal voltage step program. This pre-step allows the ions in the sample to move to the ends of the IPG strip.</p>
	Ionic detergent in sample.	<p>If the ionic detergent SDS is used in sample preparation, the final concentration must not exceed 0.25% after dilution into the rehydration solution. Additionally, the concentration of the non-ionic detergent present must be at least 8 times higher than the concentration of any ionic detergent to ensure complete removal of SDS from the proteins.</p>
	High sample load.	<p>Load less sample.</p> <p>Micropreparative separations require clean sample. Modify sample preparation to limit contaminants. (See section 1.4, 'Removal of contaminants that affect 2-D results.')</p> <p>Program a low initial voltage and increase voltage gradually. Extend focusing time.</p>



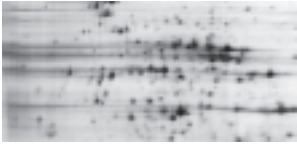
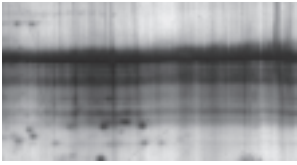

continues on following page

Table 28. Troubleshooting 2-D results (continued)

Symptom	Possible cause	Remedy
Horizontal streaking or incompletely focused spots (continued)		
	Underfocusing. Focusing time was not long enough to achieve steady state focusing.	Prolong focusing time.
	Overfocusing. Extended focusing times (over 100 000 Vh) may result in electroendosmotic water and protein movement, which can produce horizontal smearing.	Reduce focusing time.
Horizontal stripes across gel		
	Impurities in agarose overlay or equilibration solution.	Prepare fresh agarose overlay and equilibration solution.
Prominent vertical streak at the point of sample application (when loading IPG strips using sample cups)		
	(Flatbed gel format) Sample aggregation or precipitation.	Dilute the sample and apply as a larger volume. Program a low initial voltage and increase voltage gradually.
Vertical streaking		
	Insufficient equilibration.	Prolong equilibration time.
	(Flatbed gel format) Electroendosmosis.	Add 30% glycerol and 6 M urea to the SDS equilibration buffer. Place application pieces at the end of the strips during second-dimension electrophoresis to absorb excess water.
	Second-dimension buffer solutions prepared incorrectly.	Prepare fresh solutions.
	Insufficient SDS in SDS electrophoresis buffer.	Use 0.1% w/v SDS.

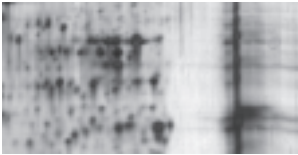

continues on following page

Table 28. Troubleshooting 2-D results (continued)

Symptom	Possible cause	Remedy
Vertical gap in 2-D pattern		
	Impurities in sample.	Modify sample preparation. (See section 1.4, 'Removal of contaminants that affect 2-D results.')
	Impurities in rehydration solution components.	Use only high-quality reagents. De-ionize urea solutions.
	Bubble between IPG strip and top surface of second-dimension gel.	Ensure that no bubbles are trapped between the IPG strip and the top surface of the second-dimension gel.
	(Flatbed gel format) Urea crystals on the surface of the IPG strip.	Allow residual equilibration solution to drain from the IPG strip before placing the strip on the second-dimension gel.
	(Flatbed gel format) Bubbles under the IPG strip.	Ensure that the IPG strip is placed firmly on the gel with no air bubbles trapped underneath. Stroke the plastic backing of the IPG strip gently with a pair of forceps to remove trapped bubbles.
Vertical regions of poor focusing		
	The IPG strip was not fully rehydrated.	Ensure that the IPG strips are rehydrated with a sufficient volume of rehydration solution. Remove any large bubbles trapped under the IPG strip after rehydration solution is applied. Check that the rehydration solution is evenly spread along the entire length of the IPG strip.
Poor representation of higher molecular weight proteins		
	Proteolysis of sample.	Prepare sample in a manner that limits proteolysis and/or use protease inhibitors. (See section 1.2, 'Protection against proteolysis.')
	Insufficient equilibration.	Prolong equilibration time.
	Poor transfer of protein from IPG strip to second-dimension gel.	Employ a low current sample entry phase in the second-dimension electrophoresis run.
	Poor entry of sample protein during rehydration.	Use recommended volume of rehydration solution. (See Table 10, page 35.)

continues on following page

Table 28. Troubleshooting 2-D results (continued)

Symptom	Possible cause	Remedy
<p>Point streaking</p> 	<p>(Silver staining). Dirty plates used to cast gel or particulate material on the surface of the gel. DTT and other thiol reducing agents exacerbate this effect.</p>	<p>Properly wash glass plates. Scavenge any excess or residual thiol reducing agent with iodoacetamide before loading the IPG strips onto the second-dimension gel.</p>
<p>Background smear toward bottom of gel</p>	<p>(Silver or Coomassie blue staining) Staining of carrier ampholytes.</p>	<p>Use IPG Buffer as carrier ampholyte mixture. Reduce concentration if necessary.</p>
<p>Background smear toward top of gel</p>	<p>(Silver staining) Nucleic acids in sample.</p>	<p>Add DNase and RNase to hydrolyze nucleic acids. <i>Note:</i> The proteins DNase and RNase may appear on the 2-D map.</p>
<p>High background in top region of gel</p> 	<p>Protein contaminant in SDS electrophoresis buffer or dirty electrophoresis unit.</p>	<p>Make fresh SDS electrophoresis buffer. Clean electrophoresis unit.</p>

Appendix I

Solutions



The acrylamide, N,N'-methylenebisacrylamide, TEMED, ammonium persulfate, and SDS in this appendix are extremely hazardous. You should have a manufacturer's safety data sheet (MSDS) detailing the properties and precautions for all chemicals in your lab. The safety sheets should be reviewed prior to starting the procedures in this manual. General handling procedures for hazardous chemicals include using double latex gloves for all protocols. Hazardous materials should be weighed in a fume hood while wearing a disposable dust mask.

A. Lysis solution

(8 M urea, 4% CHAPS, 2% Pharmalyte 3–10)

	Final concentration	Amount
Urea (FW 60.06)	8 M*	19.2 g
CHAPS†	4% (w/v)	1.6 g
Pharmalyte 3–10	2%	800 µl
Double distilled H ₂ O		to 40 ml

* If necessary, the concentration of urea can be increased to 9 or 9.8 M.

† Other detergents (Triton X-100, NP-40, and other non-ionic or zwitterionic detergents) can be used instead of CHAPS.

Note: Protease inhibitors may be added if necessary.

B. Rehydration stock solution without IPG Buffer*

(8 M urea, 2% CHAPS, 0.002% bromophenol blue)

	Final concentration	Amount
Urea (FW 60.06)	8 M†	12 g
CHAPS†	2% (w/v)	0.5 g
Bromophenol blue	0.002% (w/v)	50 µl
Double distilled H ₂ O		to 25 ml

* DTT and IPG Buffer or Pharmalyte are added just prior to use: Add 7 mg DTT per 2.5 ml aliquot of rehydration stock solution. See Table 9, page 34 for the appropriate volume of IPG Buffer or Pharmalyte to use. For rehydration loading, sample is also added to the 2.5 ml aliquot of rehydration solution just prior to use.

† If necessary, the concentration of urea can be increased to 9 or 9.8 M.

‡ Other detergents (Triton X-100, NP-40, and other non-ionic or zwitterionic detergents) can be used instead of CHAPS.

Store in 2.5 ml aliquots at -20 °C.

Bromophenol blue stock solution

	Final concentration	Amount
Bromophenol blue	1 %	100 mg
Tris-base	50 mM	60 mg
Double distilled H ₂ O		to 10 ml

C. Rehydration stock solution with IPG Buffer*

(8 M urea, 2% CHAPS, 0.5% or 2% IPG Buffer[†], 0.002% bromophenol blue, 25 ml)

	Final concentration	Amount
Urea (FW 60.06)	8 M [‡]	12 g
CHAPS [§]	2% (w/v)	0.5 g
IPG Buffer or Pharmalyte ^{††} (same range as the IPG strip)	0.5% (v/v) or 2% (v/v) [†]	125 µl or 500 µl **
Bromophenol blue	0.002%	50 µl 1% solution
Double distilled H ₂ O		to 25 ml

* DTT is added just prior to use: 7 mg DTT per 2.5 ml aliquot of rehydration stock solution. For rehydration loading, sample is also added to the 2.5-ml aliquot of rehydration solution just prior to use.

† An IPG Buffer/Pharmalyte concentration of 0.5% is recommended with the IPGphor and an IPG Buffer / Pharmalyte concentration of 2% is recommended with the Multiphor II and Immobiline DryStrip Kit system.

‡ If necessary, the concentration of urea can be increased to 9 or 9.8 M.

§ Other detergents (Triton X-100, NP-40, and other non-ionic or zwitterionic detergents) can be used instead of CHAPS.

** Use 125 µl IPG Buffer for a 0.5% concentration and 500 µl IPG Buffer for a 2% concentration.

†† Use Pharmalyte 3–10 for Immobiline DryStrip 3–10 or 3–10 NL, Pharmalyte 5–8 for Immobiline DryStrip 4–7.

Store in 2.5 ml aliquots at -20 °C.

D. SDS equilibration buffer*

(50 mM Tris-HCl, pH 8.8, 6 M urea, 30% glycerol, 2% SDS, bromophenol blue, 200 ml)

	Final concentration	Amount
Tris-HCl, pH 8.8 (see solution F)	50 mM	10.0 ml
Urea (FW 60.06)	6 M	72.07 g
Glycerol (87% v/v)	30% (v/v)	69 ml
SDS (FW 288.38)	2% (w/v)	4.0 g
Bromophenol blue	0.002% (w/v)	400 µl of 1% solution
Double distilled H ₂ O		to 200 ml

* This is a stock solution. Prior to use DTT or iodoacetamide are added. See section 3.2.2.

Store at -20 °C.

E. 30% T, 2.6% C monomer stock solution

(30% acrylamide, 0.8% N,N'-methylenebisacrylamide, 200 ml)

	Final concentration	Amount
Acrylamide (FW 71.08)	30%	60.0 g
N,N'-methylenebisacrylamide (FW 154.17)	0.8%	1.6 g
Double distilled H ₂ O		to 200 ml

Filter solution through a 0.45 µm filter. Store at 4 °C in the dark.

F. 4× resolving gel buffer

(1.5 M Tris-HCl, pH 8.8, 1 l)

	Final concentration	Amount
Tris base (FW 121.1)	1.5 M	181.7 g
Double distilled H ₂ O		750 ml
HCl (FW 36.46)		adjust to pH 8.8
Double distilled H ₂ O		to 1 l

Filter solution through a 0.45 µm filter. Store at 4 °C.

G. 10% SDS

	Final concentration	Amount
SDS (FW 288.38)	10% (w/v)	5.0 g
Double distilled H ₂ O		to 50 ml

Filter solution through a 0.45 µm filter. Store at room temperature.

H. 10% ammonium persulfate

	Final concentration	Amount
Ammonium persulfate (FW 228.20)	10% (w/v)	0.1 g
Double distilled H ₂ O		to 1 ml

Fresh ammonium persulfate "crackles" when water is added. If it does not, replace it with fresh stock. Prepare just prior to use.

I. Gel storage solution

(0.375 M Tris-HCl, pH 8.8, 0.1% SDS 200 ml)

	Final concentration	Amount
4× Resolving gel buffer (see solution F above)	1×	50 ml
10% SDS (see above)	0.1%	2 ml
Double distilled H ₂ O		to 200 ml

Store at 4 °C.

J. SDS electrophoresis buffer*

(25 mM Tris-HCl, pH 8.3, 192 mM glycine, 0.1% SDS, 10 l)

	Final concentration	Amount
Tris-base (FW 121.1)	25 mM	30.3 g
Glycine (FW 75.07)	192 mM	144.0 g
SDS (FW 288.38)	0.1% (w/v)	10.0 g
Double distilled H ₂ O		to 10 l

* Because the pH of this solution need not be checked, it can be made up directly in large reagent bottles marked at 10 l.

Store at room temperature.

K. Agarose sealing solution

	Final concentration	Amount
SDS Electrophoresis buffer (see solution J)		100 ml
Agarose (NA or M)	0.5%	0.5 g
Bromophenol blue	0.002% (w/v)	200 μ l

Add all ingredients into a 500 ml Erlenmeyer flask. Swirl to disperse. Heat in a microwave oven on low or a heating stirrer until the agarose is completely dissolved. Do not allow the solution to boil over. Dispense 2 ml aliquots into screw-cap tubes and store at room temperature.

Appendix II

Optimized silver staining of Ettan DALT gels using PlusOne Silver Staining Kit, Protein

Prepare staining reagents (250 ml per gel) according to the PlusOne Silver Staining Kit, Protein instructions with the following exceptions:

1. Prepare twice the volume of fixing solution as indicated in the Kit instructions (i.e. 500 ml per gel rather than 250 ml).
2. Prepare the developing solution with twice the volume of formaldehyde solution as indicated in the kit instructions (i.e. 100 μ l per 250 ml rather than 50 μ l per 200 ml).
3. Stain the gels according to the following protocol*:

Step	Solutions	Amount	Time
Fixation	Ethanol	200 ml	2 \times 60* min
	Acetic acid, glacial	50 ml	
	Make up to 500 ml with distilled water		
Sensitizing	Ethanol	75 ml	60 min
	Glutardialdehyde [†] (25% w/v)	1.25 ml	
	Sodium thiosulfate (5% w/v)	10 ml	
	Sodium acetate (17 g)	1 packet	
	Make up to 250 ml with distilled water		
Washing	Distilled water		5 \times 8 min
Silver reaction	Silver nitrate solution (2.5% w/v)	25 ml	60 min
	Formaldehyde [†] (37% w/v)	0.1 ml	
	Make up to 250 ml with distilled water		
Washing	Distilled water		4 \times 1 min
Developing	Sodium carbonate (6.25 g)	1 packet	5 min [‡]
	Formaldehyde [†] (37%)	100 μ l [‡]	
	Make up to 250 ml with distilled water		
	Stir vigorously to dissolve sodium carbonate		
Stop	EDTA-Na ₂ \times H ₂ O (3.65 g)	1 packet	45 min
	Make up to 250 ml with distilled water		
Washing	Distilled water		2 \times 30 min
Preservation [†]	Glycerol (87%)	25 ml	20 min
	Make up to 250 ml with distilled water		

* The first fixation may be prolonged up to 3 days if desired for convenience.

[†] By omitting glutardialdehyde from the sensitizer and formaldehyde from the silver nitrate solution, as well as omitting the "preservative step", the method becomes compatible with mass spectroscopy analysis, although sensitivity is reduced. If glutardialdehyde and formaldehyde are to be used, add them just before staining.

[‡] The volume of the formaldehyde in the developing solution can be varied between 100 μ l up to 250 μ l, depending on the amount of protein and the number of spots since formaldehyde is consumed in the developing reaction by proteins. Add the formaldehyde directly before use.

[§] Approximate time, this step may be visually monitored. The gels should be transferred to stop solution when the spots have reached the desired intensity and before the staining background becomes too dark.

References

1. O'Farrell, P.H. High resolution two-dimensional electrophoresis of proteins. *J. Biol. Chem.* **250**, 4007–4021 (1975).
2. Klose, J. Protein mapping by combined isoelectric focusing and electrophoresis of mouse tissues. A novel approach to testing for induced point mutation in mammals. *Humangenetik* **26**, 231–243 (1975).
3. Bjellqvist, B., Ek, K., Righetti, P.G., Gianazza, E., Görg, A., Westermeier, R., Postel, W. Isoelectric focusing in immobilized pH gradients: principle, methodology and some applications. *J. Biochem. Biophys. Methods* **6**, 317–339 (1982).
4. Görg, A., Postel, W., Günther, S., Weser, J. Improved horizontal two-dimensional electrophoresis with hybrid isoelectric focusing in immobilized pH gradients in the first dimension and laying-on transfer to the second dimension. *Electrophoresis* **6**, 599–604 (1985).
5. Görg, A., Postel, W., Günther, S. The current state of two-dimensional electrophoresis with immobilized pH gradients. *Electrophoresis* **9**, 531–546 (1988).
6. Wilkins, M.R., Pasquali, C., Appel, R.D., Ou, K., Golaz, O., Sanchez, J.-C., Yan, J.X., Gooley, A.A., Hughes, G., Humphrey-Smith, I., Williams, K.L., Hochstrasser, D.F. From proteins to proteomes: Large scale protein identification by two-dimensional electrophoresis and amino acid analysis. *BioTechnology* **14**, 61–65 (1996).
7. Pennington, S.R., Wilkins, M.R., Hochstrasser, D.F., Dunn, M.J. Proteome analysis: From protein characterization to biological function. *Trends in Cell Biology* **7**, 168–173 (1997).
8. Görg, A., Boguth, G., Obermaier, C., Posch, A., Weiss, W. Two-dimensional polyacrylamide gel electrophoresis with immobilized pH gradients in the first dimension (IPG-Dalt): The state of the art and the controversy of vertical *versus* horizontal systems. *Electrophoresis* **16**, 1079–1086 (1995).
9. Lenstra, J.A., Bloemendal, H. Topography of the total protein population from cultured cells upon fractionation by chemical extractions. *Eur. J. Biochem.* **135**, 413–423 (1983).
10. Molloy, M.P., Herbert, B.R., Walsh, B.J., Tyler, M.I., Traini, M., Sanchez, J.-C., Hochstrasser, D.F., Williams, K.L., Gooley, A.A. Extraction of membrane proteins by differential solubilization for separation using two-dimensional gel electrophoresis. *Electrophoresis* **19**, 837–844, (1998).
11. Ramsby, M.L., Makowski, G.S., and Khairallah, E.A. Differential detergent fractionation of isolated hepatocytes: Biochemical, immunochemical and two-dimensional gel electrophoresis characterization of cytoskeletal and noncytoskeletal compartments. *Electrophoresis* **15**, 265–277, (1994).
12. Taylor, R.S., Wu, C.C., Hays, L.G., Eng, J.K., Yates, J.R.I., and Howell, K.E. Proteomics of rat liver Golgi complex: Minor proteins are identified through sequential fractionation. *Electrophoresis* **21**, 3441–3459, (2000).
13. Deutscher, M.P. ed. Guide to Protein Purification. *Methods Enzymol.* **182**, 1–894 (1990).
14. Dunn, M.J., Corbett, J.M. 2-dimensional polyacrylamide gel electrophoresis. *Methods Enzymol.* **271**, 177–203 (1996).
15. Rabilloud, T. Solubilization of proteins for electrophoretic analysis. *Electrophoresis* **17**, 813–829 (1996).
16. Rabilloud, T., Adessi, C., Giraudel, A., Lunardi, J. Improvement of the solubilization of proteins in two-dimensional electrophoresis with immobilized pH gradients. *Electrophoresis* **18**, 307–316 (1997).

17. Bollag, D.M., Edelman, S.J. Protein Methods. Chapter 2: Protein Extraction, Wiley-Liss, NY, NY. (1991).
18. Scopes, R.K. Protein purification: Principles and practice, 2nd Ed., Chapter 2: Making an Extract, Springer Verlag, NY. (1987).
19. Dignam, J.D. Preparation of extracts from higher eukaryotes. *Methods Enzymol* **182**, 194–203 (1990).
20. Toda, T., Ishijima, Y., Matsushita, H., Yoshida, M., Kimura, N. Detection of thymopoietin-responsive proteins in nude mouse spleen cells by two-dimensional polyacrylamide gel electrophoresis and image processing. *Electrophoresis* **15**, 984–987 (1994).
21. Sanchez, J.-C., Appel, R.D., Golaz, O., Pasquali, C., Ravier, F., Bairoch, A., Hochstrasser, D.F. Inside SWISS-2DPAGE database. *Electrophoresis* **16**, 1131–1151 (1995).
22. Portig, I., Pankuweit, S., Lottspeich, F., Maisch, B. Identification of stress proteins in endothelial cells. *Electrophoresis* **17**, 803–808 (1996).
23. Cull, M., McHenry C.S. Preparation of extracts from prokaryotes. *Methods Enzymol.* **182**, 147–153 (1990).
24. Jazwinski, S.M. Preparation of extracts from yeast. *Methods Enzymol.* **182**, 154–174 (1990).
25. Kawaguchi, S.-I., Kuramitsu, S. Separation of heat-stable proteins from *Thermus thermophilus* HB8 by two-dimensional electrophoresis. *Electrophoresis* **16**, 1060–1066 (1995).
26. Teixeira-Gomes, A.P., Cloeckert, A., Bezar, G., Dubray, G., Zygmunt, M.S. Mapping and identification of *Brucella melitensis* proteins by two-dimensional electrophoresis and microsequencing. *Electrophoresis* **18**, 156–162 (1997).
27. Ames, G.F.-L., Nikaido, K. Two-dimensional gel electrophoresis of membrane proteins. *Biochemistry* **15**, 616–623 (1976).
28. Görg, A., Postel, W., Domscheit, A., Günther, S. Two-dimensional electrophoresis with immobilized pH gradients of leaf proteins from barley (*Hordeum vulgare*): Method, reproducibility and genetic aspects. *Electrophoresis* **9**, 681–692 (1988).
29. Posch, A., van den Berg, B.M., Burg, H.C.J., Görg, A. Genetic variability of carrot seed proteins analyzed by one- and two-dimensional electrophoresis with immobilized pH gradients. *Electrophoresis* **16**, 1312–1316 (1995).
30. Geigenheimer, P. Preparation of extracts from plants. *Methods Enzymol.* **182**, 174–193 (1990).
31. Theillet, C., Delpeyroux, F., Fiszman, M., Reigner, P., Esnault, R. Influence of the excision shock on the protein metabolism of *Vicia faba* L. meristematic root cells. *Planta* **155**, 478–485 (1982).
32. Wolpert, T.J., Dunkle, L.D. Alternations in gene expression in sorghum induced by the host-specific toxin from *Periconia circinata*. *Proc. Natl. Acad. Sci. USA* **80**, 6576–6580 (1983).
33. Blomberg, A., Blomberg, L., Norbeck, J., Fey, S.J., Larsen, P.M., Larsen, M., Roepstorff, P., Degand, H., Boutry, M., Posch, A., Görg, A. Interlaboratory reproducibility of yeast protein patterns analyzed by immobilized pH gradient two-dimensional gel electrophoresis. *Electrophoresis* **16**, 1935–1945 (1995).
34. Damerval, C., de Vienne, D., Zivy, M., Thiellement, H. Technical improvements in two-dimensional electrophoresis increase the level of genetic variation detected in wheat-seedling proteins. *Electrophoresis* **7**, 52–54 (1986).
35. Wu, F.-S., Wang, M.-Y. Extraction of proteins for sodium dodecyl sulfate-polyacrylamide gel electrophoresis from protease-rich plant tissues. *Anal. Biochem.* **139**, 100–103 (1984).

36. Harrison, P.A., Black, C.C. Two-dimensional electrophoretic mapping of proteins of bundle sheath and mesophyll cells of the C4 grass *Digitaria sanguinalis*. *Plant Physiol.* **70**, 1359–1366 (1982).
37. Granzier, H.L.M., Wang, K. Gel electrophoresis of giant proteins solubilization and silver-staining of titin and nebulin from single muscle fiber segments. *Electrophoresis* **14**, 56–64 (1993).
38. Colas des Francs, C., Thiellement, H., de Vienne, D. Analysis of leaf proteins by two-dimensional gel electrophoresis. *Plant Physiol.* **78**, 178–182 (1985).
39. Barret, A.J., Salversen, G. *Proteinase Inhibitors*, Elsevier Press, Amsterdam (1986).
40. North, M.J. Prevention of unwanted proteolysis. In *Proteolytic Enzymes: A Practical Approach*, (Beynon, R.J., Bond, J.S., eds.) pp 105–124, IRL Press, Oxford (1989).
41. Salvesen, G., Nagase, H. Inhibition of proteolytic enzymes. In: *Proteolytic Enzymes: A Practical Approach*, (Beynon, R.J., Bond, J.S., eds.), pp 83–104, IRL Press, Oxford (1989).
42. Hurkman, W.J., Tanaka, C.K. Solubilization of plant membrane proteins for analysis by two-dimensional gel electrophoresis. *Plant Physiol.* **81**, 802–806 (1986).
43. Granier, F. Extraction of plant proteins for two-dimensional electrophoresis. *Electrophoresis* **9**, 712–718 (1988).
44. Englard, S., Seifert, S. Precipitation techniques. *Methods Enzymol.* **182**, 285–300 (1990).
45. Cremer, F., Van de Walle, C. Method for extraction of proteins from green plant tissues for two-dimensional polyacrylamide gel electrophoresis. *Anal. Biochem.* **147**, 22–26 (1985).
46. Guy, G.R., Philip, R., Tan, Y.H. Analysis of cellular phosphoproteins by two-dimensional gel electrophoresis: Applications for cell signaling in normal and cancer cells. *Electrophoresis* **15**, 417–440 (1994).
47. Meyer, Y., Grosset, J., Chartier, Y., Cleyet-Marel, J.-C. Preparation by two-dimensional electrophoresis of proteins for antibody production: Antibodies against proteins whose synthesis is reduced by auxin in tobacco mesophyll protoplasts. *Electrophoresis* **9**, 704–712 (1988).
48. Halloway, P., Arundel, P. High-resolution two-dimensional electrophoresis of plant proteins. *Anal. Biochem.* **172**, 8–15 (1988).
49. Flengsrud, R., Kobro, G. A method for two-dimensional electrophoresis of proteins from green plant tissues. *Anal. Biochem.* **177**, 33–36 (1989).
50. Matsui, N.M., Smith, D.M., Clauser, K.R., Fichmann, J., Andrews, L.E., Sullivan, C.M., Burlingame, A.L., Epstein, L.B. Immobilized pH gradient two-dimensional gel electrophoresis and mass spectrometric identification of cytokine-regulated proteins in ME-180 cervical carcinoma cells. *Electrophoresis* **18**, 409–417 (1997).
51. Tsugita, A., Kamo, M., Kawakami, T., Ohki, Y. Two-dimensional electrophoresis of plant proteins and standardization of gel patterns. *Electrophoresis* **17**, 855–865 (1996).
52. Görg, A., Obermaier, C., Boguth, G., Csordas, A., Diaz, J.J., Madjar, J.J. Very alkaline immobilized pH gradients for two-dimensional electrophoresis of ribosomal and nuclear proteins. *Electrophoresis* **18**, 328–337 (1997).
53. Usuda, H., Shimogawara, K. Phosphate deficiency in maize. VI. Changes in the two-dimensional electrophoretic patterns of soluble proteins from second leaf blades associated with induced senescence. *Plant Cell Physiol.* **36**, 1149–1155 (1995).
54. Musante, L., Candiano, G., Ghiggeri, G.M. Resolution of fibronectin and other uncharacterized proteins by two-dimensional polyacrylamide electrophoresis with thiourea. *J. Chromat.* **705**, 351–356 (1997).

55. Pasquali, C., Fialka, I., Huber, L.A. Preparative two-dimensional gel electrophoresis of membrane proteins. *Electrophoresis* **18**, 2573–2581 (1997).
56. Rabilloud, T. Use of thiourea to increase the solubility of membrane proteins in two-dimensional electrophoresis. *Electrophoresis* **19**, 758–760 (1998).
57. Perdew, G.H., Schaup, H.W., Selivonchick, D.P. The use of a zwitterionic detergent in two-dimensional gel electrophoresis of trout liver microsomes. *Anal. Biochem.* **135**, 453–455 (1983).
58. Rabilloud, T., Blisnick, T., Heller, M., Luche, S., Aebersold, R., Lunardi, J., Braun-Bretton, C. Analysis of membrane proteins by two-dimensional electrophoresis: Comparison of the proteins extracted from normal or *Plasmodium falciparum*-infected erythrocyte ghosts. *Electrophoresis* **20**, 3603–3610 (1999).
59. Santoni, V., Molloy, M., Rabilloud, T. Membrane proteins and proteomics: Un amour impossible? *Electrophoresis* **21**, 1054–1070 (2000).
60. Wilson, D.L., Hall, M.E., Stone, G.C., Rubin, R.W. Some improvements in two-dimensional gel electrophoresis of proteins. *Anal. Biochem.* **83**, 33–44 (1977).
61. Marshall, T., Williams, K.M. Artifacts associated with 2-mercaptoethanol upon high resolution two-dimensional electrophoresis. *Anal. Biochem.* **139**, 502–505 (1984).
62. Herbert, B.R., Molloy, M.P., Gooley, A.A., Walsh, B.J., Bryson, W.G., Williams, K.L. Improved protein solubility in two-dimensional electrophoresis using tributyl phosphine as reducing agent. *Electrophoresis* **19**, 845–851 (1998).
63. Görg, A., Obermaier, C., Boguth, G., Harder, A., Scheibe, B., Wildgruber, R., Weiss, W. The current state of two-dimensional electrophoresis with immobilized pH gradients. *Electrophoresis* **21**, 1037–1053 (2000).
64. Bjellqvist, B., Sanchez, J.-C., Pasquali, C., Ravier, F., Paquet, N., Frutiger, S., Hughes, G.J., Hochstrasser, D. Micropreparative two-dimensional electrophoresis allowing the separation of samples containing milligram amounts of proteins. *Electrophoresis* **14**, 1375–1378 (1993).
65. Sanchez, J.-C., Rouge, V., Pisteur, M., Ravier, F., Tonella, L., Moosmayer, M., Wilkins, M.R., Hochstrasser, D.F. Improved and simplified in-gel sample application using reswelling of dry immobilized pH gradients. *Electrophoresis* **18**, 324–327 (1997).
66. Rabilloud, T., Valette, C., Lawrence, J.J. Sample application by in-gel rehydration improves the resolution of two-dimensional electrophoresis with immobilized pH gradients in the first dimension. *Electrophoresis* **15**, 1552–1558 (1994).
67. Westermeier, R. *Electrophoresis In Practice*, 3rd Ed., WILEY-VCH, Weinheim, (2001).
68. Sabouchi-Schütt, F., Aström, J., Olsson, I., Eklund, A., Grunewald, J., Bjellqvist, B. An Immobiline DryStrip application method enabling high-capacity two-dimensional gel electrophoresis. *Electrophoresis* **21**, 3649–3656 (2000).
69. Bjellqvist, B., Pasquali, Ch., Ravier, F., Sanchez, J.-Ch., Hochstrasser, D.F. A nonlinear wide-range immobilized pH gradient for two-dimensional electrophoresis and its definition in a relevant pH scale. *Electrophoresis* **14**, 1357–1365 (1993).
70. Görg, A., Boguth, G., Obermaier, C., Harder, A., Weiss, W. 2-D electrophoresis with immobilized pH gradients using IPGphor isoelectric focusing system. *Life Science News* **1**, 4–6 (1998).
71. Ibel, K., May, R.P., Kirschner, K., Szadkowski, H., Mascher, E., Lundahl, P. Protein-decorated micelle structure of sodium-dodecyl-sulfate protein complexes as determined by neutron scattering. *Eur. J. Biochem.* **190**, 311–318 (1990).

72. Laemmli, U.K. Cleavage of structural proteins during the assembly of the head of bacteriophage T4. *Nature* **227**, 680–685 (1970).
73. Schägger, H., von Jagow, G. Tricine-sodium dodecyl sulfate-polyacrylamide gel electrophoresis for the separation of proteins in the range from 1 to 100 kDa. *Anal. Biochem.* **166**, 368–379 (1987).
74. Görg, A., Postel, W., Weser, J., Günther, S., Strahler, J.R., Hanash, S.M., Somerlot, L. Elimination of point streaking on silver stained two-dimensional gels by addition of iodoacetamide to the equilibration buffer. *Electrophoresis* **8**, 122–124 (1987).
75. Shevchenko, A., Wilm, M., Vorm, O., Mann, M. Mass spectrometric sequencing of proteins from silver stained polyacrylamide gels. *Anal. Chem.* **68**, 850–858 (1996).
76. Neuheff, V., Stamm, R., Eibl, H. Clear background and highly sensitive protein staining with Coomassie Blue dyes in polyacrylamide gels: A systematic analysis. *Electrophoresis* **6**, 427–448 (1985).
77. Yan, J.X., Wait, R., Berkelman, T., Harry, R.A., Westbrook, J.A., Wheeler, C.H., Dunn, M.J. A modified silver staining protocol for visualization of proteins compatible with matrix-assisted laser desorption/ionization and electrospray ionization-mass spectrometry. *Electrophoresis* **21**, 3666–3672 (2000).
78. Fernandez-Patron, C., Castellanos-Serra, L., Hardy, E., Guerra, M., Estevez, E., Mehl, E., Frank, R.W. Understanding the mechanism of the zinc-ion stains of biomacromolecules in electrophoresis gels: Generalization of the reverse-staining technique. *Electrophoresis* **19**, 2398–2406 (1998).
79. Ünlü, M., Morgan, M.E., Minden, J.S. Difference gel electrophoresis: A single gel method for detecting changes in protein extracts. *Electrophoresis* **18**, 2071–2077 (1997).
80. Steinberg, T.H., Hangland, R.P., Singer, V.I. Applications of SYPRO Orange and SYPRO Red protein gel stains. *Anal. Biochem.* **239**, 238–245 (1996).
81. Steinberg, T.H., Lauber, W.M., Berggren, K., Kemper, C., Yue, S., Patton, W. Fluorescence detection of proteins in sodium dodecylsulphate-polyacrylamide gels using environmental benign, nonfixative saline solution. *Electrophoresis* **21**, 497–508 (2000).
82. Patton, W. Detecting proteins in polyacrylamide gels and on electroblot membranes. In *Proteomics: from protein sequence to function*. (Pennington, S.R., Dunn, M.J., eds.) pp 65–86, Bios Scientific Publishers Ltd. (2001).
83. Yan, J.X., Harry, R.A., Spilbey, C., Dunn, M.J. Postelectrophoretic staining of proteins separated by two-dimensional gel electrophoresis using SYPRO dyes. *Electrophoresis* **21**, 3657–3665 (2000).

Additional reading and reference material

	Code No.
Application Note: Multiple mini-format 2-D electrophoresis using precast ExcelGel and Multiphor II flatbed electrophoresis system.	80-6443-47
Application Note: Multiple mini-format 2-D electrophoresis using Hoefer standard vertical electrophoresis system.	80-6445-94
Data file: Immobiline DryStrip visualization of pH gradients.	18-1140-60
Handbook: Sample Preparation for Electrophoresis. IEF, SDS-PAGE and 2-D Electrophoresis. Principles & Methods	80-6429-60
Technical Manual: Blot processing with Processor Plus.	80-6447-27
Technical Manual: Automated silver and Coomassie staining with Processor Plus.	80-6343-34
Technical Manual: Fluorescence Imaging: principles and methods.	63-0035-28
Many of these items can be downloaded from www.amershambiosciences.com	

Recommended additional consumables

Iodoacetamide	Fluka
Thiourea	Fluka
Sulfobetains	Calbiochem
PefaBloc	Merck
SYPRO Ruby	Molecular Probes

Ordering information

Product	Quantity	Code No.
Sample Preparation		
Sample Grinding Kit	50 samples	80-6483-37
2-D Quant Kit	500 assays	80-6483-56
2-D Clean-Up Kit	50 samples	80-6484-51
SDS-PAGE Clean-Up Kit	50 samples	80-6484-70
Mini Dialysis Kit, 1 kDa cut-off, up to 250 µl	50 samples	80-6483-75
Mini Dialysis Kit, 1 kDa cut-off, up to 2 ml	50 samples	80-6483-94
Mini Dialysis Kit, 8 kDa cut-off, up to 250 µl	50 samples	80-6484-13
Mini Dialysis Kit, 8 kDa cut-off, up to 2 ml	50 samples	80-6484-32
Tris	500 g	17-1321-01
Urea	500 g	17-1319-01
CHAPS	1 g	17-1314-01
Triton X-100	500 ml	17-1315-01
Dithiothreitol (DTT)	1 g	17-1318-01
Bromophenol Blue	10 g	17-1329-01
DryStrip Cover Fluid	1 l	17-1335-01
First-dimension		
Immobiline DryStrip Reswelling Tray, for 7–18 cm IPG strips		80-6371-84
Immobiline DryStrip Reswelling Tray, for 7–24 cm IPG strips		80-6465-32
Multiphor II/Immobiline DryStrip Kit focusing system and accessories		
Multiphor II Electrophoresis Unit		18-1018-06
MultiTemp III Thermostatic Circulator, 115 V		18-1102-77
MultiTemp III Thermostatic Circulator, 230 V		18-1102-78
Immobiline DryStrip Kit		18-1004-30
Sample cups	60/pk	18-1004-35
IEF electrode strips	100/pk	18-1004-40
CleanGel electrode strips	12/pk	18-1035-33
EPS 3501 XL Power Supply		19-3500-01
Ettan IPGphor Isoelectric Focusing Unit and accessories		
Ettan IPGphor Isoelectric Focusing Unit (Order Strip Holders separately)		80-6414-02
Ettan IPGphor Protocol Guide		80-6415-73
IEF electrode strips	(100/pk)	18-1004-40
Strip Holders for use with Immobiline DryStrip and Ettan IPGphor Isoelectric Focusing Unit		
7 cm	1/pk	80-6416-87
	6/pk	80-6416-11
11 cm	1/pk	80-6417-06
	6/pk	80-6416-30
13 cm	1/pk	80-6417-25
	6/pk	80-6416-49
18 cm	1/pk	80-6417-44
	6/pk	80-6416-68
24 cm	1/pk	80-6470-07
	6/pk	80-6469-88
Ettan IPGphor Cup loading Strip Holder 7–24cm	3/pk	80-6459-43
Electrode, Cup Loading Strip Holder	6/pk	80-6464-94

Product	Quantity	Code No.
Strip Holders for use with Immobiline DryStrip and Ettan IPGphor Isoelectric Focusing Unit (continued)		
Sample Cup, Ettan IPGphor Cup Loading Strip Holder	50/pk	80-6459-81
Cleaning solution, Ettan IPGphor Strip Holder	950 ml	80-6452-78
Immobiline DryStrip gels		
7 cm	pH 3–10 L	12/pk
	pH 3–10 NL	17-6001-11
	pH 4–7	17-6001-12
	pH 6–11	17-6001-10
11 cm	pH 3–10 L	12/pk
	pH 4–7	17-6001-34
	pH 6–11	18-1016-61
13 cm	pH 3–10 L	12/pk
	pH 3–10 NL	18-1016-60
	pH 4–7	17-6001-35
	pH 6–11	17-6001-14
18 cm	pH 3–10 L	12/pk
	pH 3–10 NL	17-1234-01
	pH 4–7	17-1235-01
	pH 6–11	17-1233-01
	pH 6–9	17-6001-97
	pH 3.5–4.5	17-6001-88
	pH 4.0–5.0	17-6001-83
	pH 4.5–5.5	17-6001-84
	pH 5.0–6.0	17-6001-85
	pH 5.5–6.7	17-6001-86
24 cm	pH 3–10 L	12/pk
	pH 3–10 NL	17-6002-44
	pH 4–7	17-6002-45
	pH 6–9	17-6002-46
	pH 3–7 NL	17-6002-47
	pH 3.5–4.5	17-6002-43
	pH 4.0–5.0	17-6002-38
	pH 4.5–5.5	17-6002-39
	pH 5.0–6.0	17-6002-40
	pH 5.5–6.7	17-6002-41
Equilibration Tube Set for up to 24 cm IPG strips	12/pk	80-6467-79
IPG Buffer, 1 ml		
	pH 3.5–5.0	17-6002-02
	pH 4.5–5.5	17-6002-04
	pH 5.0–6.0	17-6002-05
	pH 5.5–6.7	17-6002-06
	pH 4–7	17-6000-86
	pH 6–11	17-6001-78
	pH 3–10	17-6000-87
	pH 3–10 NL	17-6000-88

Product	Quantity	Code No.
Pharmalyte, 25 ml		
pH 3–10		17-0456-01
pH 5–8		17-0453-01
pH 8–10.5		17-0455-01
Second dimension		
2-D Electrophoresis brochure		18-1124-82
Hoefer mini vertical units and accessories		
Hoefer miniVE complete, includes basic unit, two 10-well 1.0 mm combs, and two pairs of 1.0 mm spacers for up to 2 gels (glass plate size: 10x10.5 cm)		80-6418-77
Spacer, 1.0 mm	2/pk	80-6150-11
Spacer, 1.5 mm	2/pk	80-6150-30
SE 260 Mighty Small II Vertical Unit, complete, for 2 slab gels		80-6149-35
SE 235 Mighty Small 4-Gel Caster, complete		80-6146-12
SE 245 Mighty Small Dual Gel Caster		80-6146-50
Thin fluorescent rulers	2/pk	80-6223-83
Hoefer Wonder Wedge plate separation tool		80-6127-88
Hoefer SE 600 vertical units and accessories		
SE 600 Dual Cooled Vertical Slab Unit for up to 4 gels (glass plate size: 18x16 cm)		80-6171-58
Spacer, 1.0 mm, 1 cm wide	2/pk	80-6179-94
Spacer, 1.0 mm, 2 cm wide	2/pk	80-6180-70
Spacer, 1.5 mm, 1 cm wide	2/pk	80-6180-13
Spacer, 1.5 mm, 2 cm wide	2/pk	80-6180-89
Divider glass plate, 18x16 cm, notched		80-6179-18
SE 615 Multiple Gel Caster for 2 to 10 gels (glass plate size: 18x16 cm)		80-6182-79
Glass plates, 18x8 cm	2/pk	80-6186-59
Divider glass plate, 18x8 cm, notched		80-6186-78
Clamp assembly, 8 cm	2/pk	80-6187-35
Spacer, 1.0 mm, 1 cm wide, 8 cm long	2/pk	80-6443-09
Spacer, 1.5 mm, 1 cm wide, 8 cm long	2/pk	80-6443-28
Ettan DALT<i>twelve</i> Large Vertical System and accessories		
Ettan DALT <i>twelve</i> Separation Unit and Power Supply/Control Unit, 115 VAC		80-6466-46
Ettan DALT <i>twelve</i> Separation Unit and Power Supply/Control Unit, 230 VAC		80-6466-27
Includes:		
Ettan DALT Cassette Removal Tool	2/pk	80-6474-82
Ettan DALT Buffer Seal Removal Tool	2/pk	80-6474-63
Order accessories separately		
Ettan DALT Precast Gel Cassette		80-6466-65
Ettan DALT Gel Casting Cassette, 1.0 mm		80-6466-84
Ettan DALT Blank Cassette Insert		80-6467-03
Roller (needed for precast)		80-1106-79

Product	Quantity	Code No.
Order accessories separately (continued)		
Wonder wedge (needed for lab-cast)		80-6127-88
Ettan DALT <i>twelve</i> Gel Caster Complete Includes: 80-6467-41 and 80-6467-60		80-6467-22
Ettan DALT Separator Sheets 0.5 mm	16/pk	80-6467-41
Ettan DALT Filler Sheets 1.0 mm	6/pk	80-6467-60
Ettan DALT Cassette Rack	2/pk	80-6467-98
Ettan DALT Buffer Seal Remover Tool		80-6474-63
Ettan DALT Cassette Removal Tool		80-6474-82
Ettan DALT Glass Set	2/p	80-6475-39
Ettan DALT LF Glass Set	1 set (2 pieces)	80-6475-58
Hofer DALT Gradient Maker with peristaltic pump, 115 V		80-6067-65
Same as above, 230 V		80-6067-84
Ettan DALT gels and buffer kit		
Ettan DALT Gel 12.5% homogeneous	6/pk	17-6002-36
Ettan DALT Buffer Kit		17-6002-50
Gradient makers		
SG 30 Gradient Maker	30 ml total volume	80-6197-80
SG 50 Gradient Maker	50 ml total volume	80-6197-99
SG 100 Gradient Maker	100 ml total volume	80-6196-09
SG 500 Gradient Maker	500 ml total volume	80-6198-18
Multiphor II		
Multiphor II Electrophoresis Unit		18-1018-06
Multiphor II Buffer Strip Positioner		80-6442-90
Film remover for electrophoretic transfer		18-1013-75
IEF sample application pieces	200/pk	80-1129-46
Power supplies		
EPS 3501 Power Supply, 3500 V, 150 mA, 100 W		18-1130-04
EPS 3501 XL Power Supply, 3500 V, 400 mA, 200 W		18-1130-05
EPS 2A200 Power Supply, 200 V, 2000 mA, 200 W		80-6406-99
EPS 301 Power Supply, 300 V, 400 mA, 80 W		18-1130-01
EPS 601 Power Supply, 600 V, 400 mA, 100 W		18-1130-02
EPS 1001 Power Supply, 1000 V, 400 mA, 100 W		18-1130-03
Thermostatic circulator		
MultiTemp III Thermostatic Circulator, 115 V		18-1102-77
MultiTemp III Thermostatic Circulator, 230 V		18-1102-78
ExcelGel SDS gels		
ExcelGel SDS 2-D homogeneous	6/pk	80-6002-21
ExcelGel SDS XL 12-14	3/pk	17-1236-01
ExcelGel SDS Buffer Strips, anode and cathode	6 each/pk	17-1342-01

Product	Quantity	Code No.
PlusOne gel casting chemicals and buffers		
Acrylamide PAGE (acrylic acid < 0.05%)	250 g	17-1302-01
Acrylamide PAGE (acrylic acid < 0.05%)	1 kg	17-1302-02
Acrylamide IEF (acrylic acid < 0.002%)	250 g	17-1300-01
Acrylamide IEF (acrylic acid < 0.002%)	1 kg	17-1300-02
Acrylamide IEF, 40% solution	1 l	17-1301-01
Acrylamide PAGE, 40% solution	1 l	17-1303-01
N,N' methylenebisacrylamide	25 g	17-1304-01
N,N' methylenebisacrylamide, 2% solution	1 l	17-1306-01
Agarose M	10 g	17-0422-01
Agarose NA	10 g	17-0554-01
Glycine	500 g	17-1323-01
Ammonium persulfate	25 g	17-1311-01
TEMED	25 ml	17-1312-01
PlusOne equilibration chemicals		
Tris	500 g	17-1321-01
Urea	500 g	17-1319-01
Glycerol, 87%	1 l	17-1325-01
SDS	100 g	17-1313-01
Dithiothreitol (DTT)	1 g	17-1318-01
Bromophenol Blue	10 g	17-1329-01
Enzymes		
Deoxyribonuclease I (DNase I)	20 mg	27-0516-01
Ribonuclease I (RNase A and RNase B)	1 g	27-0330-02
Ribonuclease I "A" (RNase A)	100 mg	27-0323-01
Molecular Weight Markers		
M _r range 2 512–16 949		80-1129-83
M _r range 14 400–94 000		17-0446-01
IEF sample application pieces	200/pkg	80-1129-46
pI Calibration Kits		
Broad pI Kit, pH 3.5–9.3		17-0471-01
Low pI Kit, pH 2.5–6.5		17-0472-01
High pI kit, pH 5–10.5		17-0473-01
Carbamylyte Calibration Kit		17-0582-01
Automated and Multiple Gel Staining		
Silver Staining Kit, Protein		17-1150-01
Hoefer Processor Plus Base Unit		80-6444-04
PTFE coated stainless steel tray, 19×29 cm.		80-6444-80
Accepts gels up to 16×26 cm.		

Product	Quantity	Code No.
Automated and Multiple Gel Staining (continued)		
PTFE coated stainless steel tray, 29×35 cm. Accepts gels up to 28×26 cm.		80-6445-18
Blot Processing Tray Pack		80-6444-23
Protocol Guide, Hoefer Automated Gel Stainer		80-6343-34
Staining Tray Set		80-6468-17
Coomassie tablets, PhastGel Blue R-350		17-0518-01
SYPRO Orange Protein Gel Stain	500 µl	RPN5801
SYPRO Orange Protein Gel Stain	10×50 µl	RPN5802
SYPRO Red Protein Gel Stain	500 µl	RPN5803
SYPRO Red Protein Gel Stain	10×50 µl	RPN5804
SYPRO Tangerine Protein Gel Stain	500 µl	RPN5805
SYPRO Gel Stain Starter Kit, 1×50 µl of each plus Photographic Filter and Protein Molecular Weight Markers		RPN5811
Gel driers		
Hoefer SE 1200 Easy Breeze™ Air Gel Drier, 115V		80-6121-61
Hoefer SE 1200 Easy Breeze Air Gel Drier, 115V		80-6121-80
Gel Loading Platform for gels up to 25×21 cm		80-6429-41
Gel Frame for gels up to 25×21 cm		80-6429-22
Cellophane Sheets, 33×38 cm	50/pk	80-6430-17
Gel Loading Platform for gels up to 20×20 cm		80-6429-22
Gel Frame for gels up to 20×20 cm		80-6429-22
Cellophane Sheets, 33×33 cm	50/pk	80-6121-99
Hoefer GD 2000 Vacuum Gel Drier for gels up to 33×44 cm, 115 V		80-6428-84
Hoefer GD 2000 Vacuum Gel Drier for gels up to 33×44 cm, 230 V		80-6429-03
Cellophane Sheets		80-6117-81
ImageMaster Image Analysis System		
ImageScanner		18-1134-45
Typhoon 8600		63-0027-96
Typhoon 9200		Inquire
Typhoon 9400		Inquire
Ettan Progenesis Software, 1.0		18-1154-43
ImageMaster 2D Elite Software		80-6350-56
ImageMaster 2D Database Software		80-6351-13
Spot Handling		
Ettan Spot Picker		18-1145-28
Ettan Digester		Inquire
Ettan Spot Handling Workstation		Inquire
Mass Spectrometry		
Ettan MALDI-ToF, 120 V		18-1145-00
Ettan MALDI-ToF, 230 V		18-1142-33

CleanGel, Ettan, Eazy Breeze, ExcelGel, Hoefler, ImageMaster, ImageScanner, Immobililine, IPGphor Multiphor, MultiTemp, Pharmalyte, PlusOne and Typhoon are trademarks of the Amersham Biosciences group.

Amersham and Amersham Biosciences are trademarks of Amersham plc.

Coomassie is a trademark of ICI plc.

SYPRO is a trademark of Molecular Probes Inc.

Tris and Triton X-100 are trademarks of Rohm & Haas.

Tween is a trademark of ICI Americas Inc.

All goods and services are sold subject to the terms and conditions of sale of the company within the Amersham Biosciences group that supplies them. A copy of these terms and conditions is available on request. © Amersham Biosciences AB 2001 - All rights reserved.

Amersham Biosciences AB

AB Björkgatan 30, SE-751 84 Uppsala, Sweden

Amersham Biosciences

Amersham Place, Little Chalfont, Buckinghamshire HP7 9NA, England

Amersham Biosciences Corp

800 Centennial Avenue, PO Box 1327, Piscataway, NJ 08855 USA

Amersham Biosciences Europe GmbH

Munzinger Strasse 9, D-79111 Freiburg, Germany

Amersham Biosciences

Sanken Building, 3-25-1, Shinjuku-ku, Tokyo 169-0073, Japan

www.amershambiosciences.com

