

EE 172 Extra Credit Project

2.4 GHz Yagi-Uda Antenna

Created by

**Mario Delgadillo
Maringan Pardamean Pangabean**



Abstract

This report will define antenna theory and design as it relates to a Yagi-Uda Antenna type. Antenna theory will originate from Electromagnetic field equations, while expected design parameters will be simulated via software and the actual design characteristics will be measured. This Yagi antenna consisted of the driven element, a reflecting element and four directing elements. The material for our design consisted of an aluminum sheet, copper tape, thin plastic, and a large threaded N-connector. The primary requirement for the antenna was that it operated in the 2.4 GHz range. Another objective was to predict its gain and verify the prediction. We built the Yagi antenna and predicted it would radiate at 6.2dB of directional gain, we measured 5.5dB.

TABLE OF CONTENTS

1. Introduction	4
2. Theory	5
3. Procedure	9
4. Results	13
5. Discussion	15
References	16
Appendix A (Half Wave Dipole Antenna Radiation Pattern Derivation)	17
Appendix B (Current and Power based on Number of Elements).....	19
Appendix C (Excel Data)	21

Introduction

The fundamentals of our antenna project are described through basic antenna characteristics. In general this starts with establishing the antenna's radiation pattern, gain and directivity. The radiation pattern is a 2-D or 3D plot which assesses the intensity in which electromagnetic waves propagates as a function of orientation. The gain of an antenna indicates how well the signal power amplifies in one direction, where its directivity characterizes the direction and magnitude of maximum power amplification.

The design of a Yagi (Yagi-Uda) antenna requires proper understanding of how the components are structured and how varying the lengths and position of these components changes the characteristics of the antenna. The components include a driver, reflector(s), and a number of directors. The driver is the single active element which is excited by a signal, while the reflector(s) re-radiate by reflecting the signal and directors re-radiate by directing the signal. For this reason both the reflector(s) and directors are considered as parasitic elements. A common starting point for a design begins with selecting the length of the director such that is it slightly less than one-half of the intended operating wavelength. In the report other general guidelines and specific details showcase the design choices as they relate to antenna performance. In addition to our design we have examined the characteristics of a commercially available Yagi Antenna that being the WSJ-1800 which operates at 2.4 GHz as well.

Theory

Antennas are devices that transmit or receive electromagnetic waves. If an antenna is receiving a signal it converts the incident electromagnetic waves into electrical currents; if it is transmitting it does the opposite. Antennas are designed to radiate (or receive) electromagnetic energy with particular radiation and polarization properties suited for its specific application.

The Yagi antenna is a directional antenna which consists of a dipole and several parasitic elements. The parasitic elements in a Yagi antenna are the reflectors and the directors. A Yagi antenna typically has only one reflector which is slightly longer than the driving element (dipole) and several directors, which are slightly shorter than the driving element. The Yagi antenna is said to be directional because it radiates power in one direction allowing it to transmit and receive signals with less interference in that particular direction. Figure 1 is a diagram of the general configuration of a Yagi antenna.

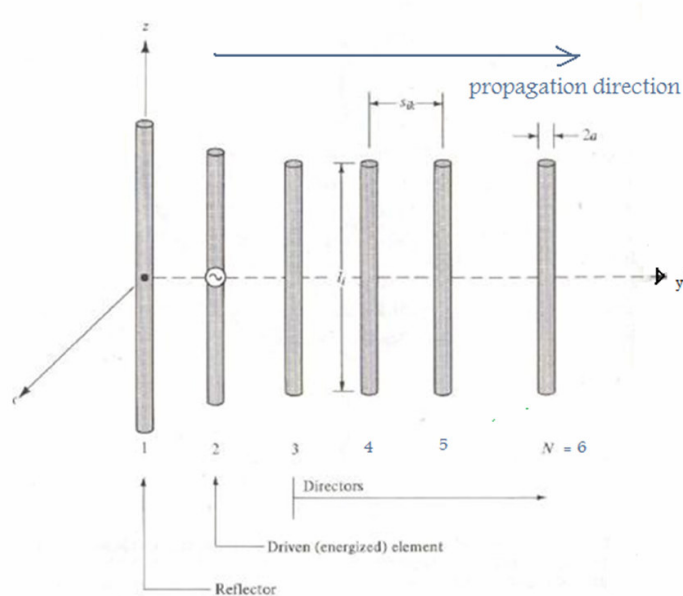

Figure 1. Yagi Antenna Configuration

The directionality of an antenna can be determined from the relative distribution characteristics of the radiated power from the antenna; this is known as an antenna's radiation pattern. Given the electric and magnetic field patterns of an antenna, the time-average Poynting vector, also known as the power density equation, can be obtained using the following formula:

$$S_{av} = \frac{1}{2} \Re(\mathbf{E} \times \mathbf{H})$$

Where \mathbf{E} and \mathbf{H} are the electric and magnetic field equations. The radiation pattern is typically described in terms the normalized radiation intensity, which is given by:

$$F(\theta, \phi) = \frac{S(R, \theta, \phi)}{S_{\max}}$$

Where R is the range, θ is the called the elevation plane which corresponds to a constant value of ϕ . If $\phi = 0$ then the x - z plane is defined. The ϕ angle is referenced through the azimuth plane and specified by $\theta = 90^\circ$ (x - y plane). Figure 2 summarizes these parameters.

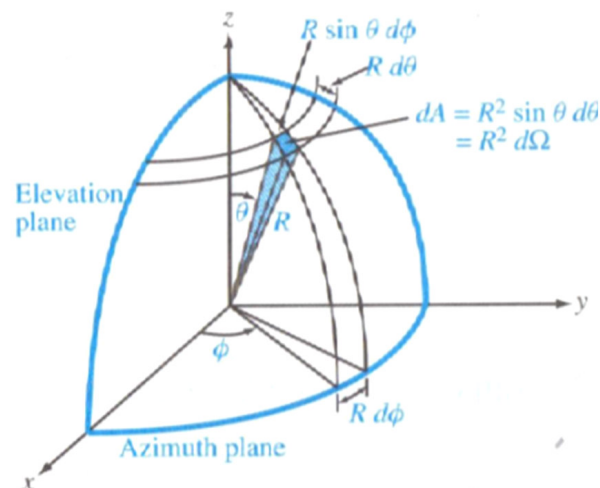

Figure 2. Definition of R , θ , and ϕ .

The radiation pattern of a Half-Wave Dipole Antenna is shown below. Once the electric and magnetic field equations for the Half-Wave Dipole Antenna are solved then a radiation pattern can be calculated. Please refer to the Appendix for the derivation of the electric and magnetic wave equations which lead to the calculation of the radiation pattern.

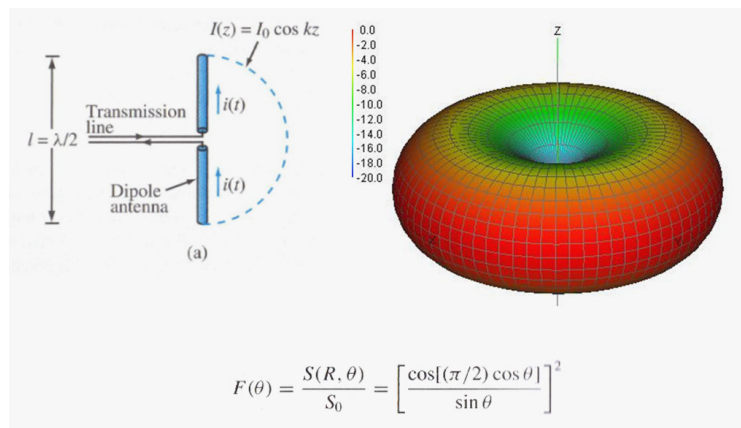
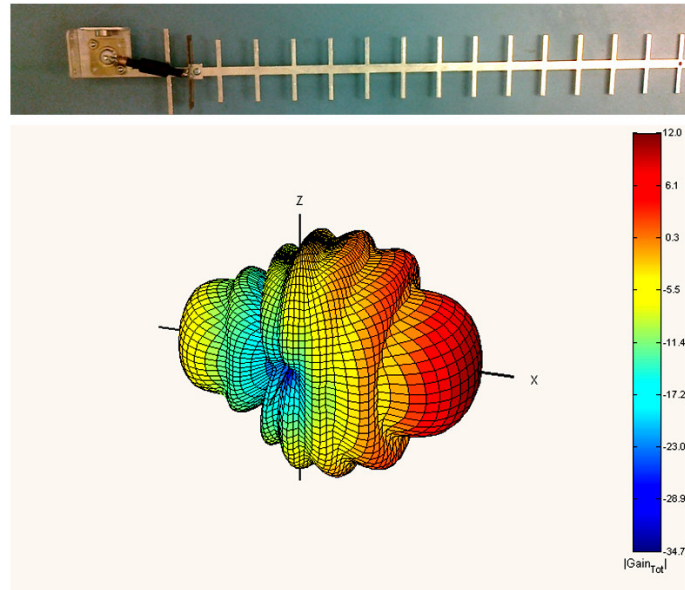

Figure 3. Half-Wave Dipole Antenna and Radiation Pattern

Notice that the Half-Wave Dipole Antenna radiates its power equally in a radial fashion, along the x-y plane in Figure 3.

The radiation pattern for a commercial MFJ-1800, a 2.4 GHz Wi-Fi operation Yagi antenna is shown below. Refer to the Appendix for an abbreviated derivation of the radiation pattern of a Yagi antenna.



$$F_T(\theta, \phi) = \sin \theta \sum_{n=1}^M I_n e^{j\psi_n} \left[\sum_{m=1}^M (-1)^m \frac{(2m-1) I_{mn} \cos\left(\frac{\pi I_n}{\lambda} \cos \theta\right)}{(2m-1)^2 - \left(\frac{2I_n}{\lambda} \cos \theta\right)^2} \right]$$

Figure 4. MFJ-1800 Yagi Antenna and its Radiation Patten

Notice that the radiation pattern shows a very directive beam, which indicates that the MFJ-1800 Yagi Antenna radiates with the greatest directional power along the x-direction.

The general guidelines for determining the size and shape of a Yagi antenna include accounting for the reflector length, driver length, director lengths, reflector to driver spacing, driver to first director spacing, and the spacing between the directors. The directional gain of a Yagi antenna is typically 7-9dB per λ (wavelength) of overall antenna length (given as a multiple of wavelengths). There is little to no gain by the addition of more than one reflector. Adding directors however, does increase the overall directive gain of the antenna, but not indefinitely. Generally the reflector length is slightly greater than $\lambda/2$, the driver and director lengths are slightly less than $\lambda/2$, director lengths are typically between $0.4-0.45\lambda$. The reflector to driver spacing is about $\lambda/4$. The

spacing between directors can be between $n \cdot 0.2$ to 0.4λ , but be aware when the director spacing is greater than 0.3λ the overall gain of the antenna is decreased by 5-7dB.

Procedure

The Yagi antenna that was built for this project was made from an aluminum sheet. The aluminum sheet was cut out using pliers and filed down to the specific dimensions. The driving element was shaped from a thin plastic sheet and then covered with copper tape. The Yagi antenna was built this way for two reasons: the aluminum sheet and copper tape were cheap and also easy to work with. The drawback of cutting out the Yagi antenna from an aluminum sheet was that the design became final upon cutting and no further adjustments are then possible.

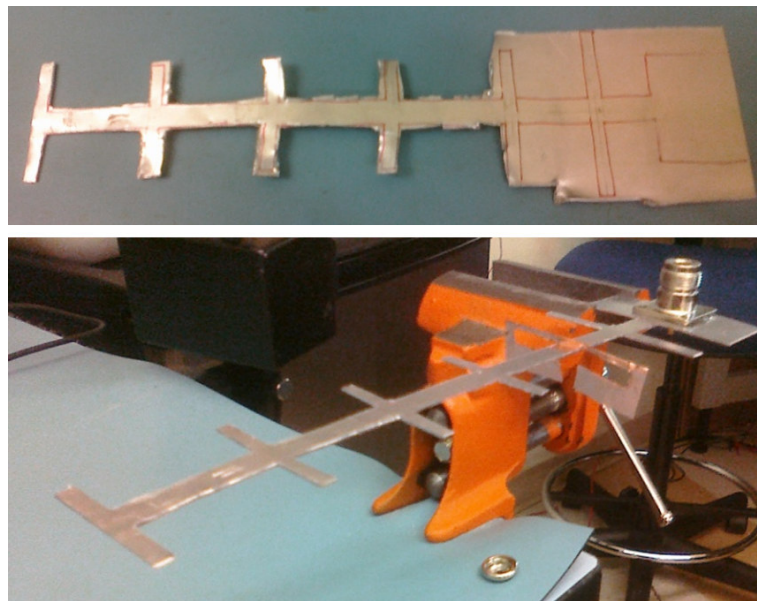

Figure 5. Cutting out the parasitic elements. The final design.

Figure 6 is a general schematic of the Yagi antenna which was built. The six lengths that are listed in the schematic are of the specific lengths that were previously explained. The list below summarizes those lengths.

$$\lambda = c / f = (3 \times 10^8) / (2.4 \times 10^9) = 0.125 \text{ m} = 125 \text{ mm}$$

$$L1 \text{ (director spacing)} \approx 42 \text{ mm} = 0.34 \lambda$$

$$L2 \text{ (driver to director)} \approx 35 \text{ mm} = 0.28 \lambda$$

$$L3 \text{ (reflector to driver)} \approx 35 \text{ mm} = 0.28 \lambda$$

$$L4 \text{ (directors length, } < (\lambda/2) < L5) \approx 41 \text{ mm} = 0.33 \lambda$$

$$L5 \text{ (driver length, } < (\lambda/2)) \approx 60 \text{ mm} = 0.48 \lambda$$

$$L6 \text{ (reflector length, } > L5 > (\lambda/2)) \approx 64 \text{ mm} = 0.51 \lambda$$

$$L7 \text{ (antenna length)} \approx 200 \text{ mm} = 1.6 \lambda$$

$$\text{Expected gain} = 1.6 \lambda (7\text{dB}/\lambda) - 5\text{dB} = 6.2\text{dB}$$

The expected gain is antenna gain was calculated by using two of the general rules for designing a Yagi antenna. These rules were described in the Theory section of this report. Expect a 7-9dB gain per λ (overall length of antenna) and also a 5-7dB loss if the director lengths exceed 0.3λ . In our design the antenna was 1.6λ in total length and the drivers were slightly over 0.3λ so we naturally assumed about a 5dB loss.

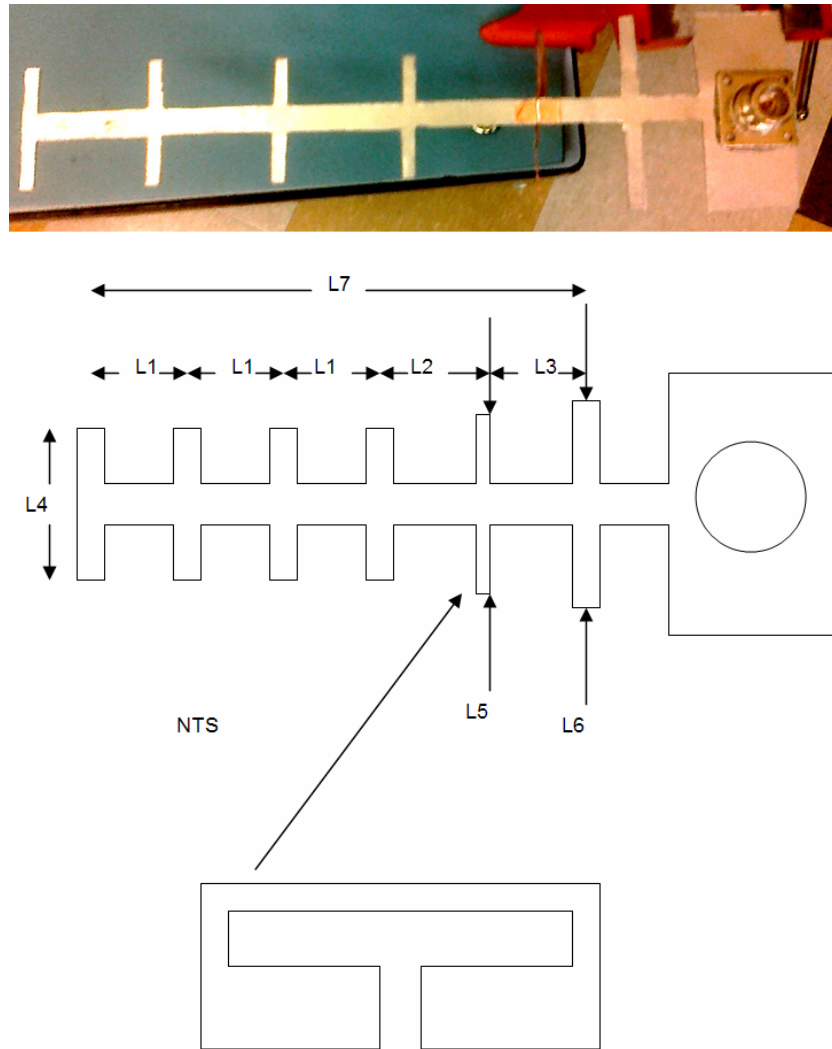

Figure 6. Overall Design of the Yagi Antenna

In order to determine how our Yagi antenna would radiate we decided to use a very common software application which calculated and plotted the three dimensional radiation patterns for typical antennas. This professional software tool is called Super NEC 2.9, which we obtained a 30-day trial version which has functions that integrated with MATLAB. Super NEC has a built-in template for a Yagi antennas which allowed us to simply input the Yagi antenna's element spacing's and Super NEC generated a three dimensional model of the antenna, as shown in Figure 7.

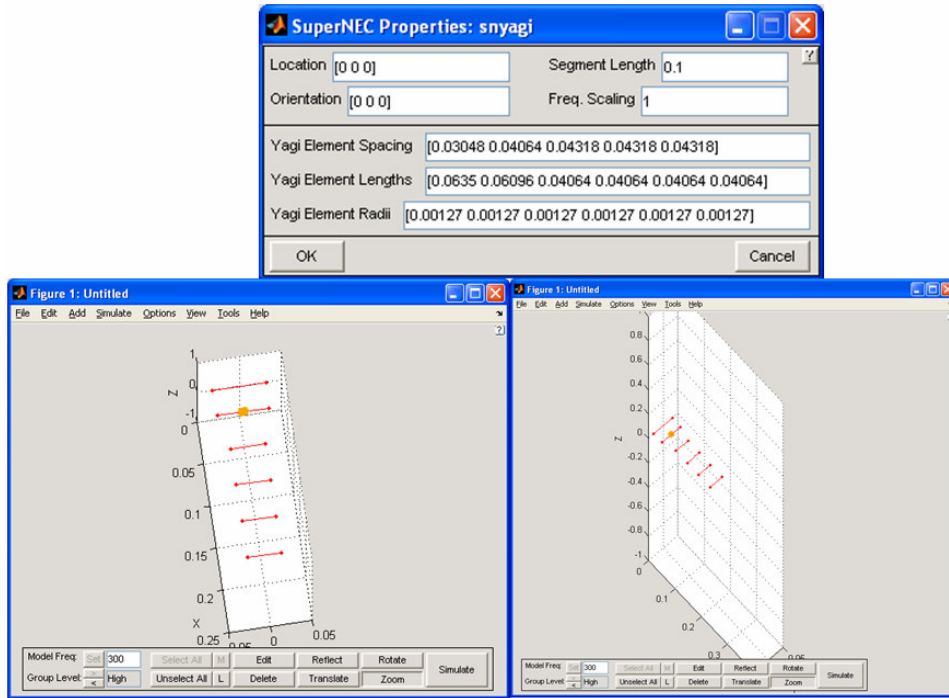

Figure 7. Super NEC Input Parameters (top) and Generated Model (bottom)

Once the antenna has the desired dimensions, then Super NEC can generate three dimensional radiation plots of the antenna. As shown on Figure 8.

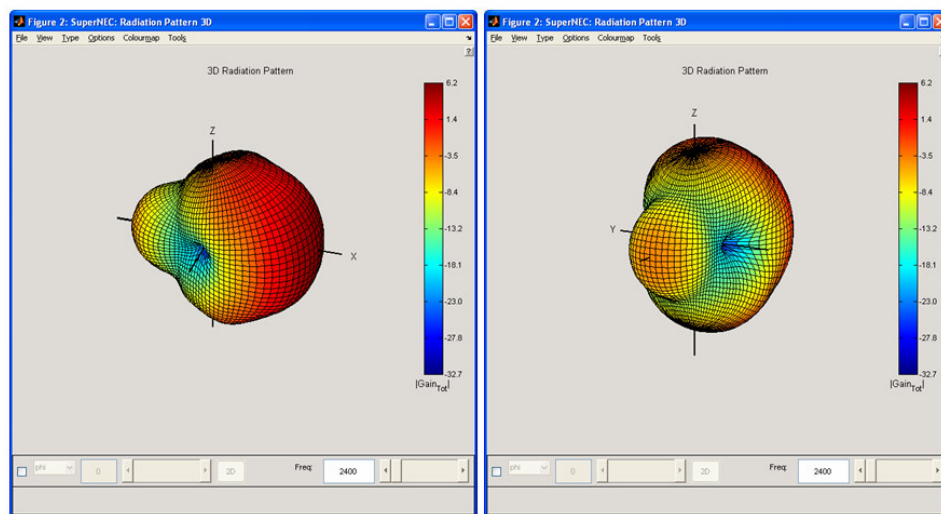

Figure 8. Super NEC Radiation Pattern Calculation for our Yagi Antenna

As expected the predicted directivity gain (at max) is 6.2dB, which aligned with our predicted expectations.

Results

We verified our design at Palm, Inc. Palm has a calibrated setup for measuring radiation patterns of antennas. The first step that was taken prior to placing the antenna in a chamber for measurements was to verify that the antenna could in fact transmit a signal. With the use of a spectrum analyzer the S_{11} parameter was measured; if the S_{11} had been 0dBm this indicates the entire signal that is being put into the antenna is reflected back and not transmitted at all. Ideally we want the S_{11} to be as low as possible at the desired operating frequency.

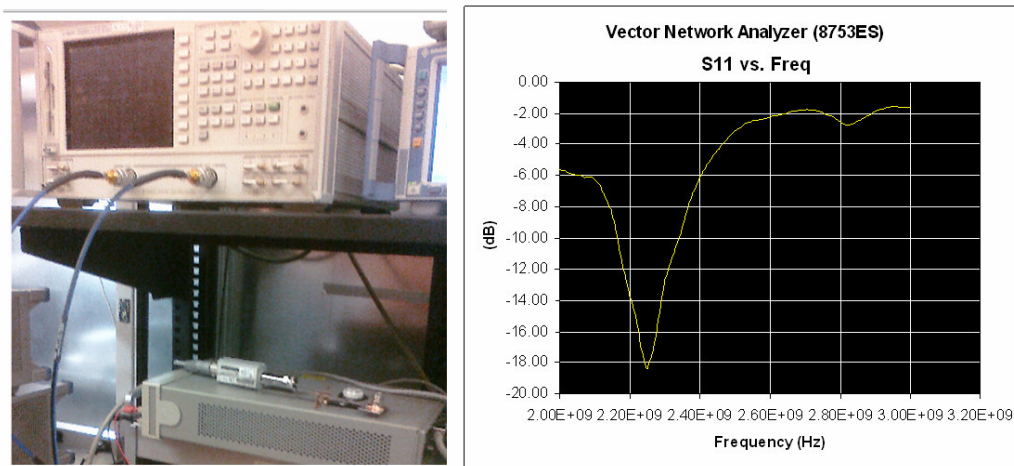

Figure 9. S_{11} Measurement Results

As the graph shows the antenna transmitted the best at about 2.3GHz, which is not the intended frequency of 2.4GHz, yet it still performs well at 2.4GHz with the S_{11}

parameter at -6dB. This low value indicates that the antenna does transmit at the operating frequency, but could improve its efficiency from a more optimized design.

Once we verified that the Yagi antenna did in fact transmit then we placed it in the radiation chamber (Figure 10). Inside this chamber the antenna is mechanically rotated while an automated program gathered all the relevant data then generated a three dimensional radiation pattern graph as shown in Figure 11. The measured radiation pattern yielded 5.54dB gain which is 0.7dB less than what we had expected.

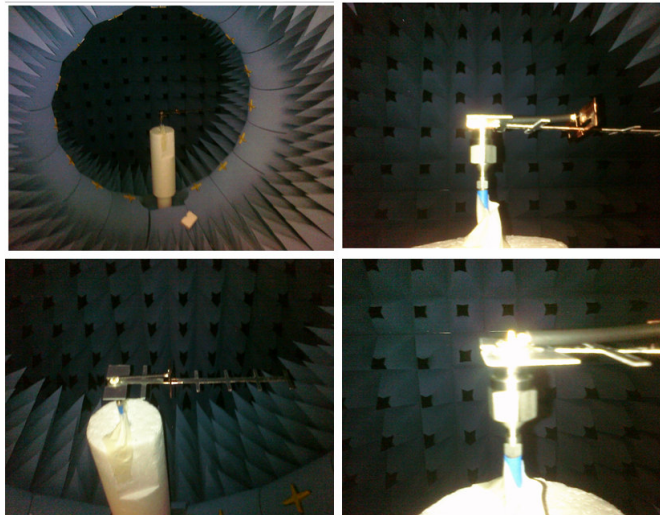

Figure 10. Calibrated Radiation Chamber for Antenna Radiation Pattern Measurements

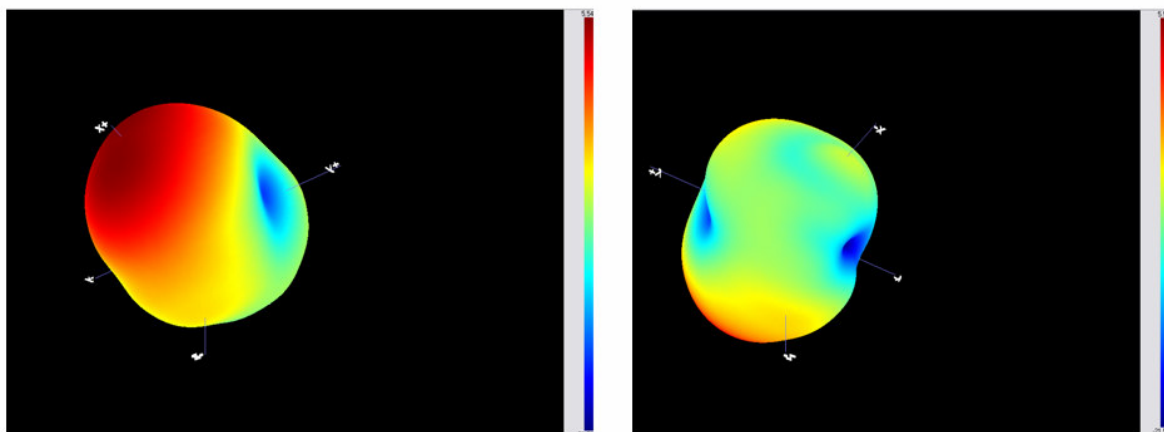

Figure 11. Measured Radiation Pattern

Discussion

The overall gain closely correlated to the theoretical gain, which came as a surprise to us since we had not performed any matching on the antenna. We simply used 50ohm cable to solder the N-connector to the driving element and counted on it to work from our theory understanding. The relief came to us once we had performed the S_{11} measurement and verified that it was transmitting. Consequently we were confident that a radiation pattern measurement would be possible.

The major issue in our design was the fact that we did not pay attention to the loss of directive gain if we made the director spacing too large, above 0.3λ . We lost 5dB in gain because of this oversight. The problem was due to the fact that once we cut out the antenna out of the aluminum sheet we could not undo it, and cutting another sheet would take us another four hours. This is why using an aluminum sheet is difficult.

On the other side, this antenna was very cheap. It cost about \$8 to build, \$3.50 of which was the N-Connector. And even with the 5dB loss we still produced an antenna which was directional which allowed for better reception and transmission in one particular direction. The radiation pattern did indeed greatly resemble the predicted radiation pattern.

References

Balanis, C.A. (1982). *Antenna Theory: Analysis and Design*
New York, NY: Harper & Row

Elliot, Robert S. (2003). *Antenna Theory and Design*
Hoboken, NJ: John Wiley & Sons Inc

Ulaby, F.T. (2005). *Electromagnetics for Engineers*
Upper Saddle River, NJ: Pearson Education

Appendix A – Radiation Pattern Derivation

Half Wave Dipole Antenna Radiation Pattern Derivation

Short Dipole

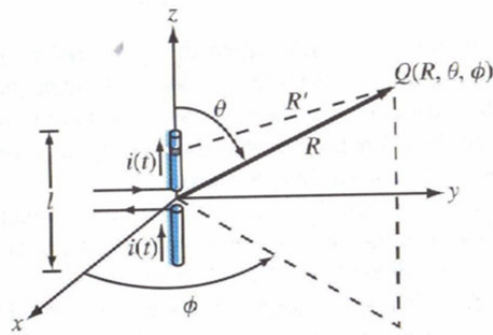

$$i(t) = I_0 \cos \omega t = \Re\{I_0 e^{j\omega t}\} \quad (\text{A})$$

$$\tilde{E}_\theta = \frac{j I_0 l k \eta_0}{4\pi} \left(\frac{e^{-jkR}}{R} \right) \sin \theta \quad (\text{V/m}) \quad \tilde{H}_\phi = \frac{\tilde{E}_\theta}{\eta_0}$$

Half-Wave Dipole Antenna

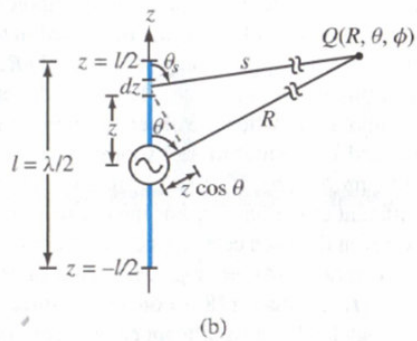
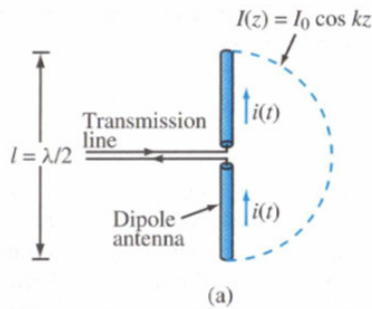

$$s \simeq R - z \cos \theta$$

$$d\tilde{E}_\theta(z) = \frac{jk\eta_0}{4\pi} \tilde{I}(z) dz \left(\frac{e^{-jks}}{s} \right) \sin \theta_s,$$

$$d\tilde{E}_\theta = \frac{jk\eta_0}{4\pi} \tilde{I}(z) dz \left(\frac{e^{-jkR}}{R} \right) \sin \theta e^{jkz \cos \theta}$$

$$\tilde{E}_\theta = \int_{z=-\lambda/4}^{\lambda/4} d\tilde{E}_\theta.$$

$$\tilde{E}_\theta = j 60 I_0 \left[\frac{\cos[(\pi/2) \cos \theta]}{\sin \theta} \right] \left(\frac{e^{-jkR}}{R} \right) \quad \tilde{H}_\phi = \frac{\tilde{E}_\theta}{\eta_0}$$

1/2 Wave Antenna Radiation Pattern

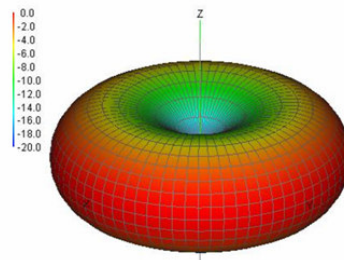
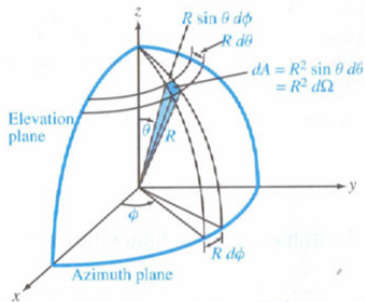

Time Averaging Pointing Vector / Power Density

$$S_{av} = \frac{1}{2} \Re \left(\tilde{\mathbf{E}} \times \tilde{\mathbf{H}}^* \right) \quad (\text{W/m}^2)$$

$$F(\theta) = \frac{S(R, \theta)}{S_0} = \left[\frac{\cos[(\pi/2) \cos \theta]}{\sin \theta} \right]^2$$

$$F(\theta, \phi) = \frac{S(R, \theta, \phi)}{S_{max}} \quad (\text{dimensionless})$$

Yagi Antenna Radiation Pattern Equation

Appendix B – Current and Power based on number of elements

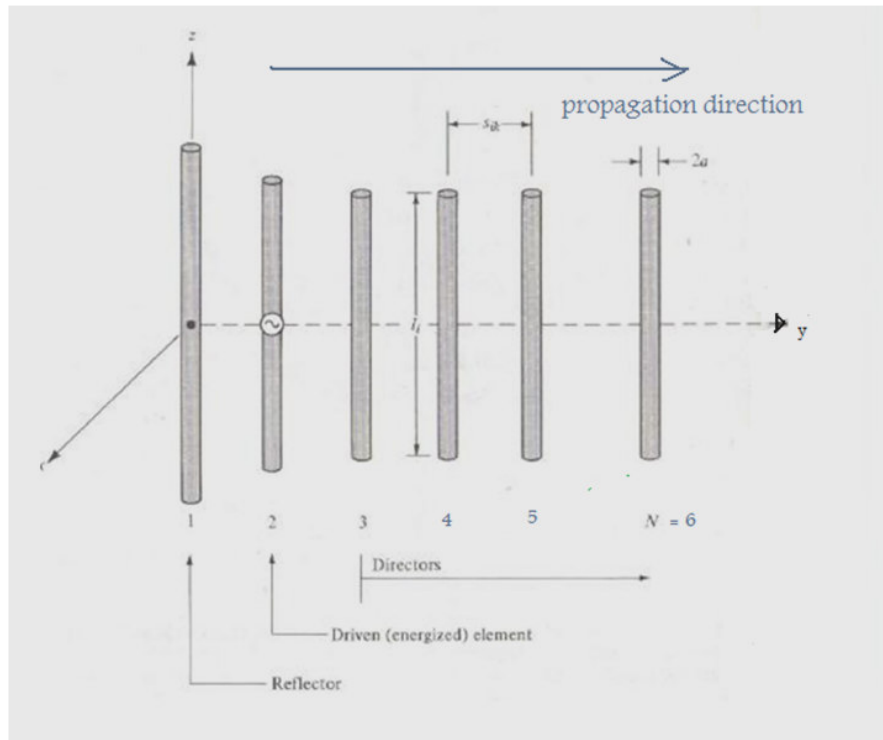

Current of the n-th element

$$I_n(z') = \sum_{m=1}^M I_{mn} \cos\left[(2m-1) * \frac{(\pi z')}{l_n}\right] \quad \text{for } m = 1, 2, 3, 4$$

I_{mn} = Complex current coefficient of mode m, element n

l_n = Length of the n element

Power Radiation

- For N elements with M modes the total E field

is given by
$$E_{\theta} = \sum_{n=1}^N E_{\theta n} = -j\eta \cdot \frac{e^{-jkr}}{4r} \cdot F_T(\theta, \phi)$$

where:

$$F_T(\theta, \phi) = \sin \theta \sum_{n=1}^N \left\{ I_n e^{j\Psi_n} \left[\sum_{m=1}^M (-1)^m \cdot \frac{(2m-1) \cdot I_{mn} \cos\left(\frac{\pi I_n}{\lambda} \cos \theta\right)}{(2m-1)^2 - \left(\frac{2I_n}{\lambda} \cos \theta\right)^2} \right] \right\}$$

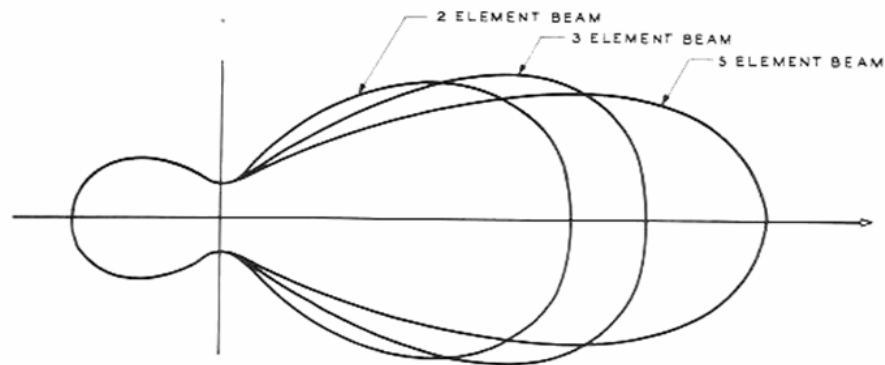

Appendix C – Excel Data

Excel Data: Calculating Radiation Pattern

Element length name	Length (meters)
L_1	0.06875
L_2	0.0625
L_3	0.0375
L_4	0.0375
L_5	0.0375
L_6	0.0375

Appendix Table 1: Actual Element Length

Element current name	Relative current fraction of i_2
i_1	0.8
i_2	1
i_3	0.2
i_4	0.15
i_5	0.1
i_6	0.5

Appendix Table 2: Fractional Current in Each Element

Excel Data: Calculating Radiation Pattern

$\lambda=0.125\text{m}$
m (mode) 1

θ (deg)	θ (rad)	Σ (m)	Σ (n)	$\sin\theta\Sigma$ (m,n)	ABS	log
-90	-1.571	-2.750	-0.773	0.773	0.773	2.231
-85	-1.484	-2.758	-0.776	0.773	0.773	2.238
-80	-1.396	-2.788	-0.784	0.772	0.772	2.247
-75	-1.309	-2.854	-0.803	0.775	0.775	2.211
-70	-1.222	-3.004	-0.845	0.794	0.794	2.005
-65	-1.134	-3.424	-0.963	0.873	0.873	1.183
-60	-1.047	-6.115	-1.720	1.490	1.490	3.461
-55	-0.960	0.447	0.126	-0.103	0.103	19.746
-50	-0.873	-1.174	-0.330	0.253	0.253	11.943
-45	-0.785	-1.506	-0.424	0.299	0.299	10.473
-40	-0.698	-1.627	-0.458	0.294	0.294	10.629
-35	-0.611	-1.677	-0.472	0.270	0.270	11.358
-30	-0.524	-1.695	-0.477	0.238	0.238	12.455
-25	-0.436	-1.699	-0.478	0.202	0.202	13.896
-20	-0.349	-1.696	-0.477	0.163	0.163	15.750
-15	-0.262	-1.690	-0.475	0.123	0.123	18.200
-10	-0.175	-1.685	-0.474	0.082	0.082	21.694
-5	-0.087	-1.681	-0.473	0.041	0.041	27.702
0.00001	0.000	-1.684	-0.474	0.000	0.000	141.651
5	0.087	-1.681	-0.473	-0.041	0.041	27.702
10	0.175	-1.685	-0.474	-0.082	0.082	21.694
15	0.262	-1.690	-0.475	-0.123	0.123	18.200
20	0.349	-1.696	-0.477	-0.163	0.163	15.750
25	0.436	-1.699	-0.478	-0.202	0.202	13.896
30	0.524	-1.695	-0.477	-0.238	0.238	12.455
35	0.611	-1.677	-0.472	-0.270	0.270	11.358
40	0.698	-1.627	-0.458	-0.294	0.294	10.629
45	0.785	-1.506	-0.424	-0.299	0.299	10.473
50	0.873	-1.174	-0.330	-0.253	0.253	11.943
55	0.960	0.447	0.126	0.103	0.103	19.746
60	1.047	-6.115	-1.720	-1.490	1.490	3.461
65	1.134	-3.424	-0.963	-0.873	0.873	1.183
70	1.222	-3.004	-0.845	-0.794	0.794	2.005
75	1.309	-2.854	-0.803	-0.775	0.775	2.211
80	1.396	-2.788	-0.784	-0.772	0.772	2.247
85	1.484	-2.758	-0.776	-0.773	0.773	2.238
90	1.571	-2.750	-0.773	-0.773	0.773	2.231

Appendix Table 3: Mode 1

Excel Data: Calculating Radiation Pattern

$\lambda=0.125\text{m}$

mode 2

θ (deg)	Σ (m)	Σ (n)	$\sin\theta\Sigma$ (m,n)	m1 + m2	ABS	log
-90	0.917	0.258	-0.258	0.516	0.516	5.753
-85	0.910	0.256	-0.255	0.518	0.518	5.716
-80	0.891	0.251	-0.247	0.525	0.525	5.590
-75	0.859	0.242	-0.233	0.542	0.542	5.323
-70	0.817	0.230	-0.216	0.578	0.578	4.761
-65	0.765	0.215	-0.195	0.678	0.678	3.380
-60	0.707	0.199	-0.172	1.317	1.317	2.394
-55	0.643	0.181	-0.148	-0.251	0.251	12.005
-50	0.576	0.162	-0.124	0.129	0.129	17.805
-45	0.508	0.143	-0.101	0.198	0.198	14.051
-40	0.442	0.124	-0.080	0.214	0.214	13.385
-35	0.379	0.107	-0.061	0.209	0.209	13.587
-30	0.322	0.090	-0.045	0.193	0.193	14.282
-25	0.270	0.076	-0.032	0.170	0.170	15.402
-20	0.227	0.064	-0.022	0.141	0.141	16.997
-15	0.192	0.054	-0.014	0.109	0.109	19.246
-10	0.166	0.047	-0.008	0.074	0.074	22.598
-5	0.151	0.042	-0.004	0.038	0.038	28.519
0	0.146	0.041	0.000	0.000	0.000	142.437
5	0.151	0.042	0.004	-0.038	0.038	28.519
10	0.166	0.047	0.008	-0.074	0.074	22.598
15	0.192	0.054	0.014	-0.109	0.109	19.246
20	0.227	0.064	0.022	-0.141	0.141	16.997
25	0.270	0.076	0.032	-0.170	0.170	15.402
30	0.322	0.090	0.045	-0.193	0.193	14.282
35	0.379	0.107	0.061	-0.209	0.209	13.587
40	0.442	0.124	0.080	-0.214	0.214	13.385
45	0.508	0.143	0.101	-0.198	0.198	14.051
50	0.576	0.162	0.124	-0.129	0.129	17.805
55	0.643	0.181	0.148	0.251	0.251	12.005
60	0.707	0.199	0.172	-1.317	1.317	2.394
65	0.765	0.215	0.195	-0.678	0.678	3.380
70	0.817	0.230	0.216	-0.578	0.578	4.761
75	0.859	0.242	0.233	-0.542	0.542	5.323
80	0.891	0.251	0.247	-0.525	0.525	5.590
85	0.910	0.256	0.255	-0.518	0.518	5.716
90	0.917	0.258	0.258	-0.516	0.516	5.753

Appendix Table 4: Mode 1 and Mode 2 contribution

Excel Data: Calculating Radiation Pattern

$\lambda=0.125\text{m}$

mode 3

θ (deg)	Σ (m)	Σ (n)	$\sin\theta\Sigma$ (m,n)	m1 + m2 + m3	ABS	log
-90	-0.605	-0.170	0.170	0.686	0.686	3.278
-85	-0.602	-0.169	0.169	0.686	0.686	3.269
-80	-0.592	-0.167	0.164	0.689	0.689	3.230
-75	-0.577	-0.162	0.157	0.699	0.699	3.115
-70	-0.557	-0.157	0.147	0.725	0.725	2.791
-65	-0.531	-0.149	0.135	0.813	0.813	1.798
-60	-0.501	-0.141	0.122	1.439	1.439	3.164
-55	-0.467	-0.131	0.108	-0.144	0.144	16.861
-50	-0.429	-0.121	0.092	0.221	0.221	13.102
-45	-0.390	-0.110	0.077	0.276	0.276	11.188
-40	-0.348	-0.098	0.063	0.277	0.277	11.147
-35	-0.306	-0.086	0.049	0.259	0.259	11.745
-30	-0.265	-0.075	0.037	0.230	0.230	12.748
-25	-0.227	-0.064	0.027	0.197	0.197	14.123
-20	-0.191	-0.054	0.018	0.160	0.160	15.933
-15	-0.162	-0.045	0.012	0.121	0.121	18.356
-10	-0.139	-0.039	0.007	0.081	0.081	21.837
-5	-0.125	-0.035	0.003	0.041	0.041	27.839
0	-0.120	-0.034	0.000	0.000	0.000	141.787
5	-0.125	-0.035	-0.003	-0.041	0.041	27.839
10	-0.139	-0.039	-0.007	-0.081	0.081	21.837
15	-0.162	-0.045	-0.012	-0.121	0.121	18.356
20	-0.191	-0.054	-0.018	-0.160	0.160	15.933
25	-0.227	-0.064	-0.027	-0.197	0.197	14.123
30	-0.265	-0.075	-0.037	-0.230	0.230	12.748
35	-0.306	-0.086	-0.049	-0.259	0.259	11.745
40	-0.348	-0.098	-0.063	-0.277	0.277	11.147
45	-0.390	-0.110	-0.077	-0.276	0.276	11.188
50	-0.429	-0.121	-0.092	-0.221	0.221	13.102
55	-0.467	-0.131	-0.108	0.144	0.144	16.861
60	-0.501	-0.141	-0.122	-1.439	1.439	3.164
65	-0.531	-0.149	-0.135	-0.813	0.813	1.798
70	-0.557	-0.157	-0.147	-0.725	0.725	2.791
75	-0.577	-0.162	-0.157	-0.699	0.699	3.115
80	-0.592	-0.167	-0.164	-0.689	0.689	3.230
85	-0.602	-0.169	-0.169	-0.686	0.686	3.269
90	-0.605	-0.170	-0.170	-0.686	0.686	3.278

Appendix Table 5: Mode 1 and Mode 2 and Mode 3 Contribution

Excel Data: Calculating Radiation Pattern

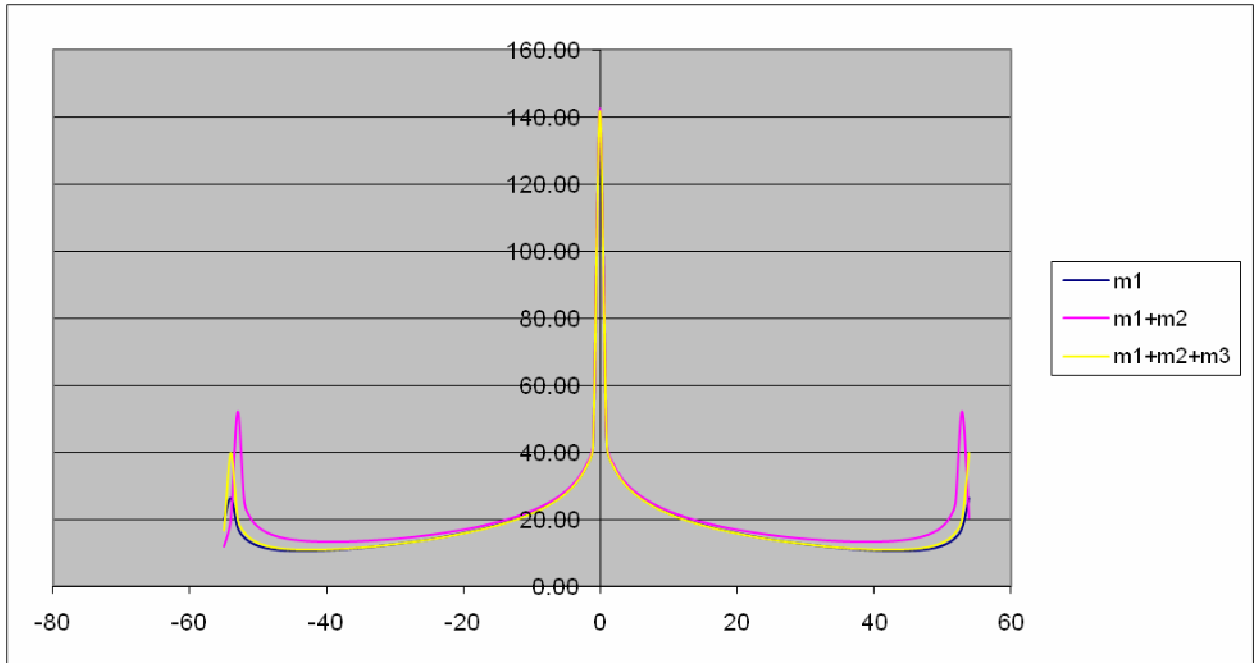

Appendix Figure: Plot of Calculate Radiation Pattern
Data from five tables above